

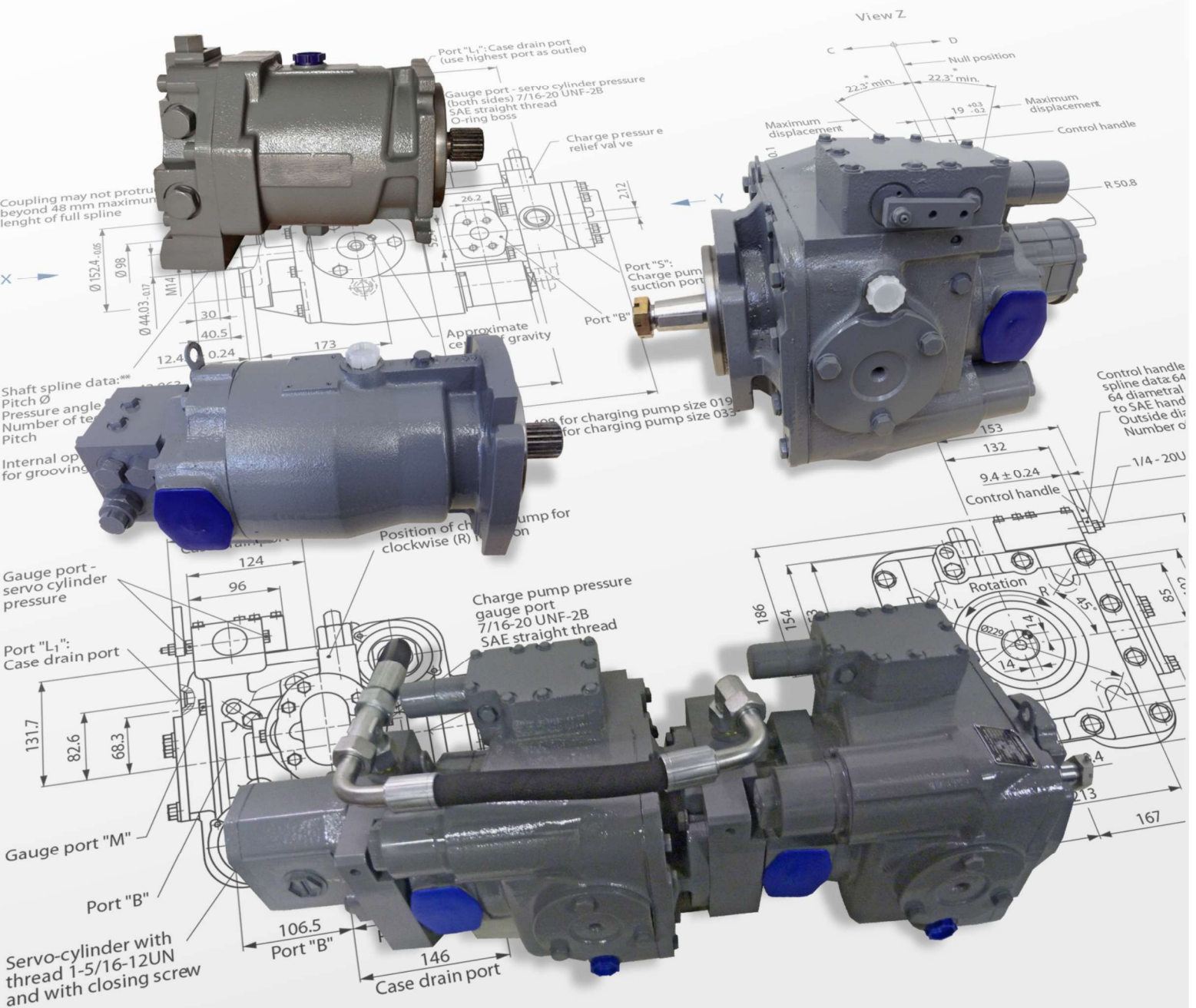

TRADEWILL

... moving your machines

AXIAL PISTON PUMPS AND MOTORS SERIES 20



CONTENTS

	Page No.
AXIAL PISTON PUMPS SERIES 20	2 - 23
- General description	2
- Features	3
- Technical data	4
- Servo displacement control	6
- Reversing time	7
- Dimensions.....	8 – 9
- Hose & pipe connection	10
- Input shaft details	11
- PV 24	12
- PV 25	13
- PV 26	14
- PV 27	15
- PV model code	16
- Types of control	17
- PVS short version	18-20
- Tandem pumps PVS	21
- Spare parts for PV pumps	22
- Spare parts for PVS pumps	23
AXIAL PISTON MOTORS SERIES 20	24 - 36
- General description	24
- Technical data	25
- DimensionsMF 20-21-22-23.....	26 - 27
- Dimesnions MF 25-26-27.....	28 - 29
- Hose flange & piping	30
- Manifold assy	31
- MF model code	32
- Spare parts for MF motors.....	33
- MV variable motors	34-35
- Short Motors MFS	36-37

GENERAL DESCRIPTION

Axial piston variable displacement pumps Series 20 are of swash plate construction with variable flow capability suitable for hydrostatic transmissions with closed circuit.

The flow rate is depending on the pump's driven speed displacement, which is determined by swash plate angle. Tilting the swash plate to the opposite side of the neutral or zero displacement position reverses flow direction.

Figure 1:

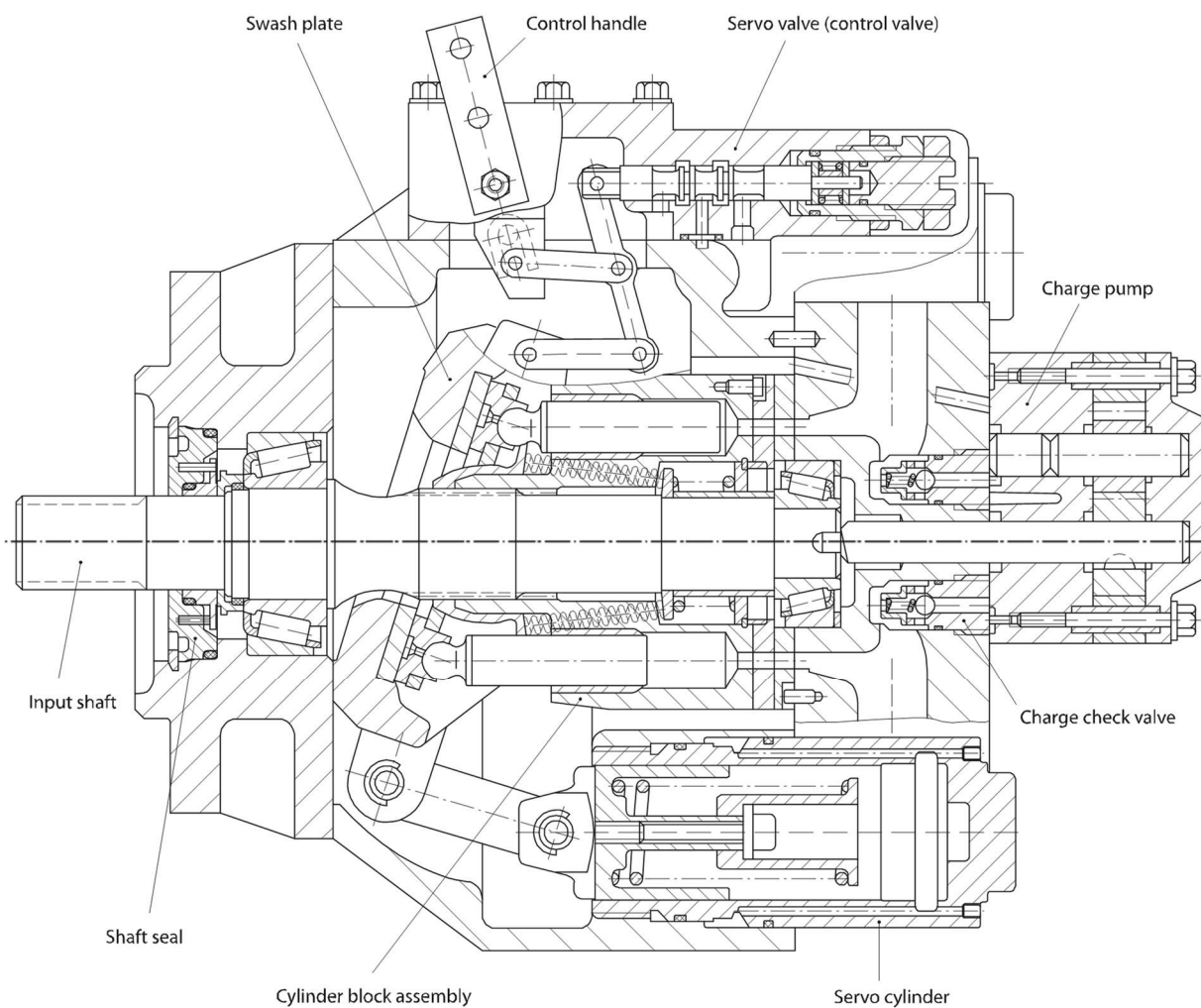

FEATURES

Axial piston variable displacement pumps Series 20 are well – engineered and easy handle. The full – length shaft with a highly efficient tapered roller bearing arrangement offers a high loading capacity for external radial forces. Additional pumps can be built on. The hydro – mechanical servo displacement control maintains the selected swash plate position and hence pumps displacement. Upon release of the control handle, the swash plate automatically returns to the null position and the flow becomes zero. High case pressures can be achieved without leakage even at the lowest temperatures by using suitable shaft seals. The servo valve arrangement offers the facility to incorporate function regulators and remote control systems. Axial piston units are designed for easy servicing, complete dismantling and disassembly can be carried out with standard hand tools, and all components or sub – assemblies are replaceable.

Figure 2 shows schematically the function of hydrostatic transmission using an axial piston variable displacement pump and fixed displacement motor.

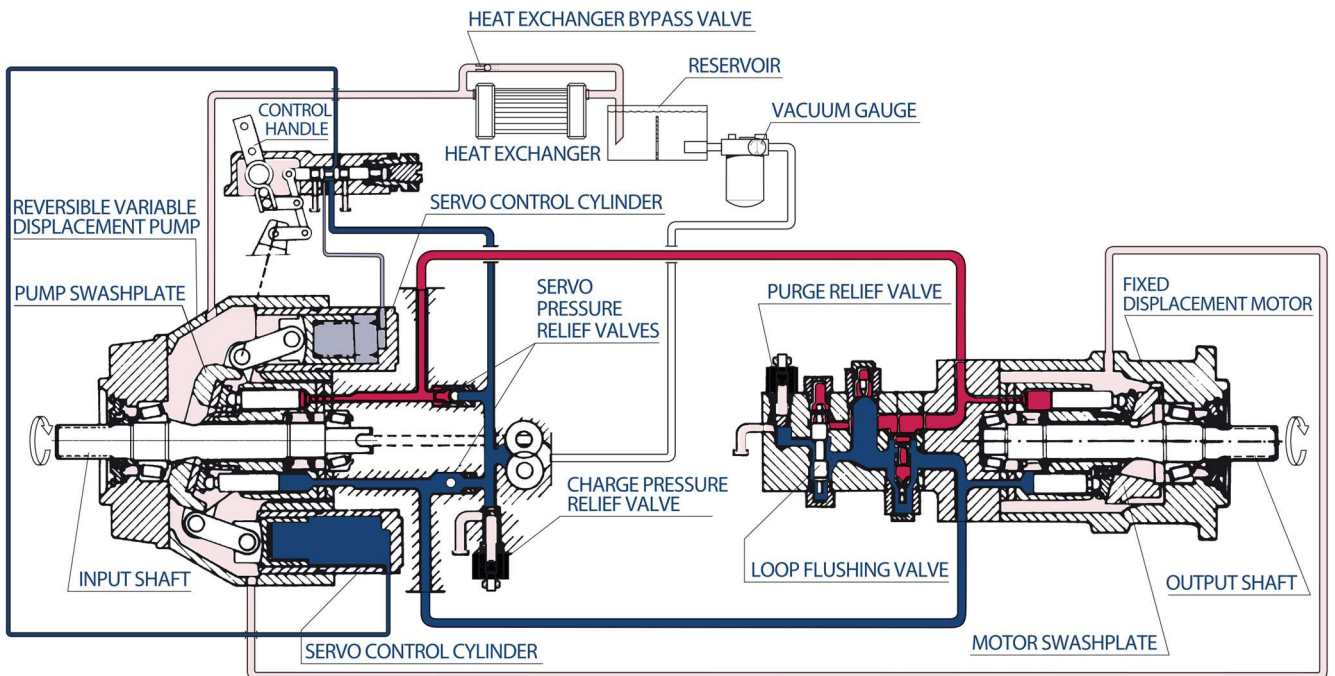

■ WORKING LOOP (HIGH PRESSURE)
 ■ WORKING LOOP (LOW PRESSURE)
 ■ CONTROL FLUID
 SUCTION LINE
 ■ CASE DRAIN FLUID

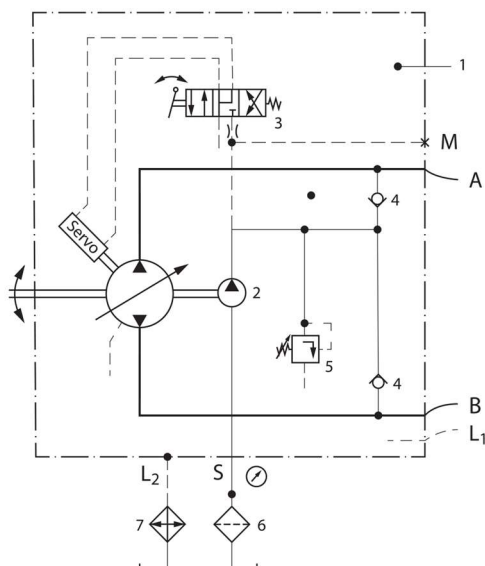

Designation:

- 1 = Variable displacement pump
- 2 = Charge pump
- 3 = Servo control valve
- 4 = Charge check valve
- 5 = Charge relief valve
- 6 = Filter
- 7 = Heat exchanger

Ports:

- A, B = Main pressure ports (working loop)
- S = Suction port - charge pump

LI, L2=Drain ports

M = Gauge port - charge pressure

TECHNICAL DATA

Table 1:

Parameter	Dimension	Frame size								
		20	21	22	23	112	24	25	26	27
Max. displacement per revolution of the variable displacement pump	cm ³	33,3	51,6	69,8	89,0	110,8	118,7	165,8	227,3	333,7
Max. flow	dm ³ min ⁻¹	119	160	196	230	288	279	348	429	557
Displacement per revolution of the charge pump	cm ³	12,30	12,30	18,03	18,03	18,03	32,80	32,80	32,80	65,50
Max. pressure	MPa	35 – 42								
Nominal pressure	MPa	21								
Max. pressure of control	MPa	3,5								
Charge pressure	MPa	0,8 - 2,0								
Max. pressure in case	MPa	0,25 continuous 0,5 intermittent								
Maximum speed	min ⁻¹	3590	3100	2810	2600	2600	2350	2100	1890	1670
Minimum speed	min ⁻¹	500								
Nominal speed	min ⁻¹	1500								
Kinematic viscosity range of working fluid	mm ² s ⁻¹	1000 12-600 25-35								
-starting										
-operating										
-optimum										
Working fluid		mineral oil								
Operating temperature	°C	-40 to +50								
Max. temperature of working fluid in tank	°C	80								
Purity of working fluid	µm	10								
Direction of shaft rotation		clockwise or counter clockwise								
Maximum swash plate angle	°	±18°								
Weight	kg	51	61	63	80	80	124	164	212	270

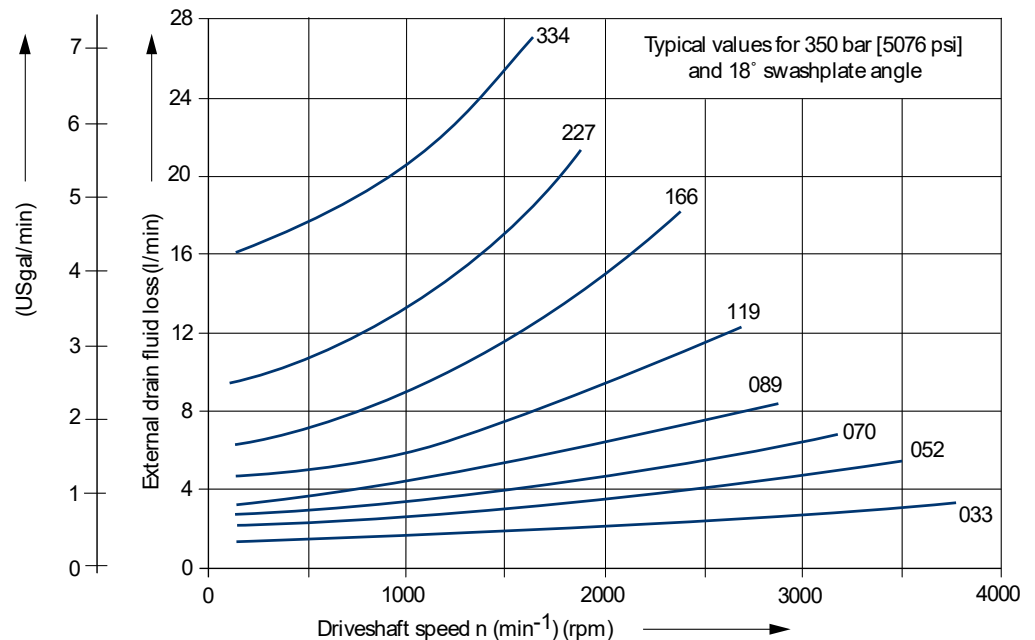
 Figure 3. External drain fluid loss for frame sizes 20 – 27
 Determination of nominal pump size

EXAMPLES OF CURVES DEPENDENCES OF EFFICIENCY FLOW AND OUTPUT ON THE SPEED (for operating condition of 18° swash plate angle)

For frame size 20

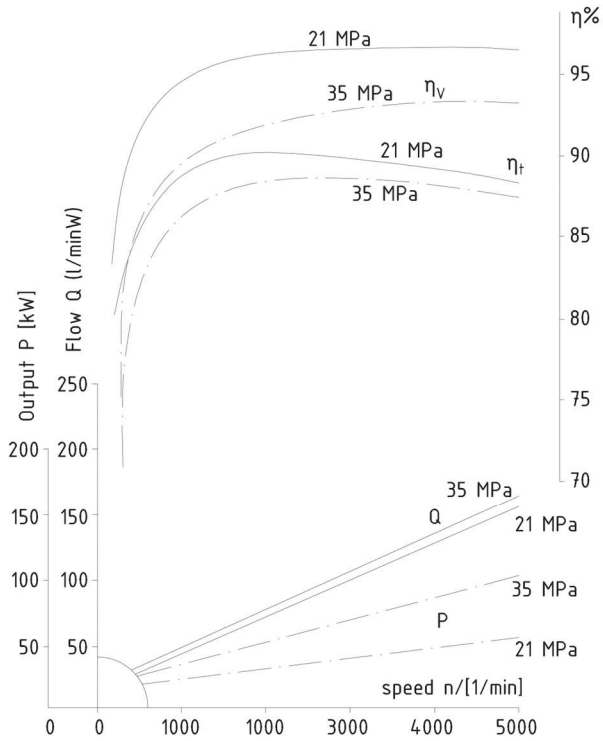

For frame size 22

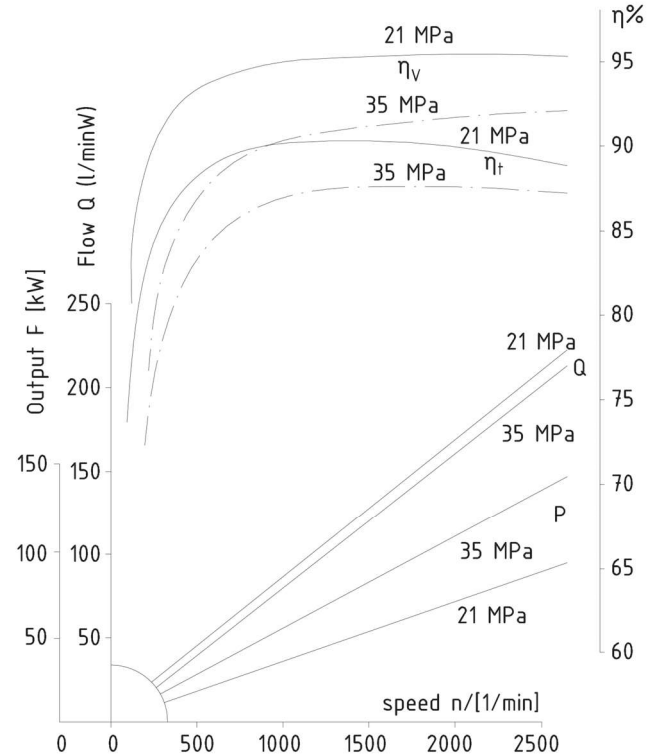

For frame size 23

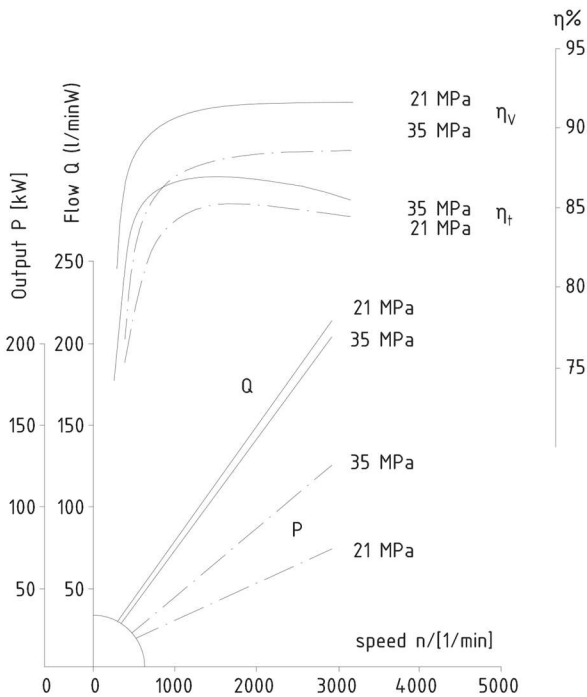

pump output flow

$$Q_e = \frac{g \cdot n \cdot \eta_v}{1000} \quad (\text{l/min})$$

Input torque

$$M_e = \frac{15,9 \cdot V_g \cdot \Delta p}{100 \cdot \eta_{mh}} \quad (\text{Nm})$$

Input power

$$P_e = \frac{M_g \cdot n}{9550} = \frac{Q_e \cdot \Delta p}{600 \eta_t} \quad (\text{kW})$$

- V_m - displacement (cm³) per revolution
- Δp - difference high and low pressure (MPa)
- n - speed (min⁻¹)
- η_v - volumetric efficiency
- η_{mh} - mechanical – hydraulic efficiency
- η_t - total efficiency

SERVO DISPLACEMENT CONTROL (linear response)

Regulated by the control handle on the servo valve, the swash plate can be infinitely varied in both directions with the help of the servo system.

The pump displacement resulting from any control handle position can be established using figures as showed below.

The angle of the control handle for stroke initiation and for the final position of the stroke can vary from unit to unit within the range of the tolerance.

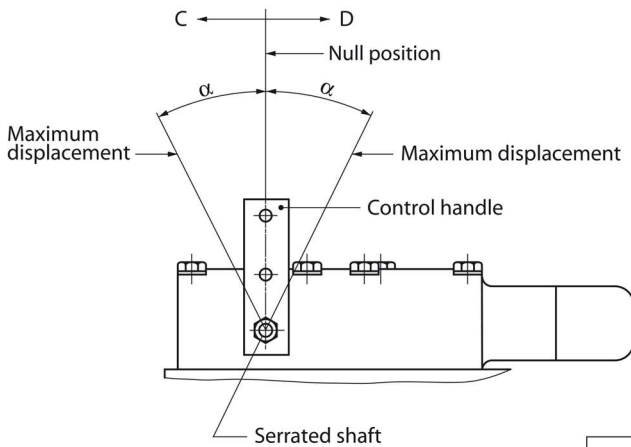

Frame size 20

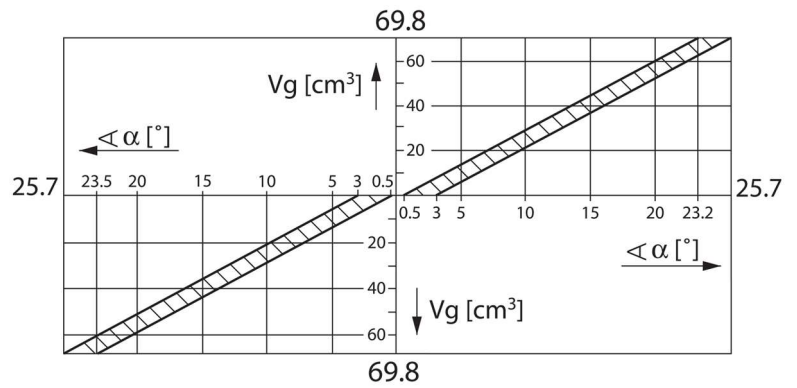

Frame size 22

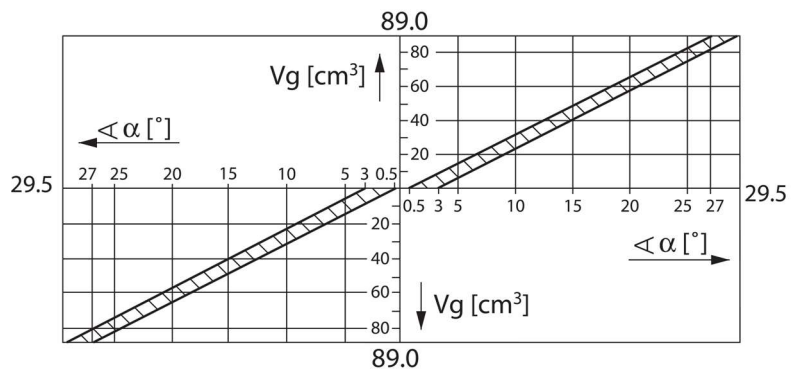

Frame size 23

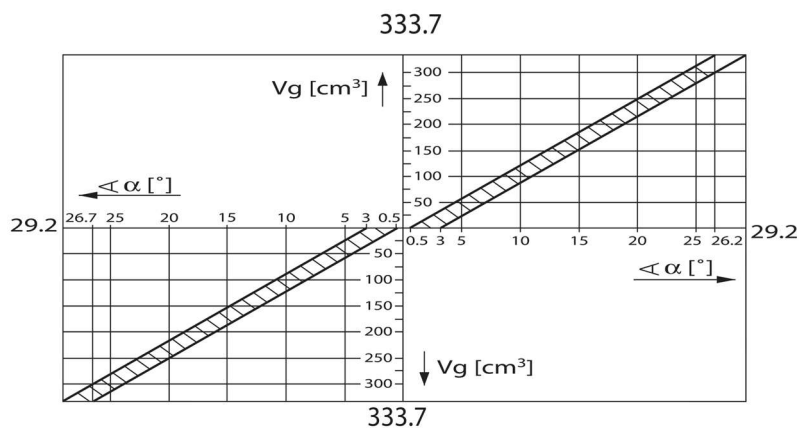

REVERSING TIME

Time for the directional change of the flow from Q max across 0 to Q max depending on the size of the control orifice fitted in the supply port to the servo valve.

The values given assume movement of the control handle directly from one end position to other.

Adjustment time of handle: < minimum reversing time
 Operating pressure: 21 MPa
 Speed: 1450 min⁻¹
 Viscosity: 35 mm².s⁻¹

Schematic diagram of servovalve with Alternative orifice position

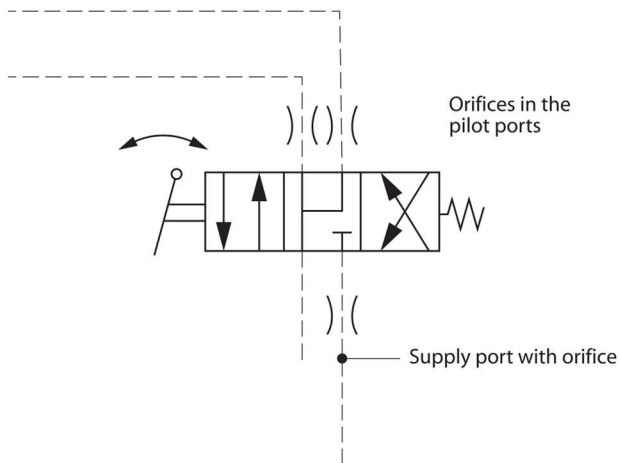

Servo valve counterbored recessed for Orifices insert

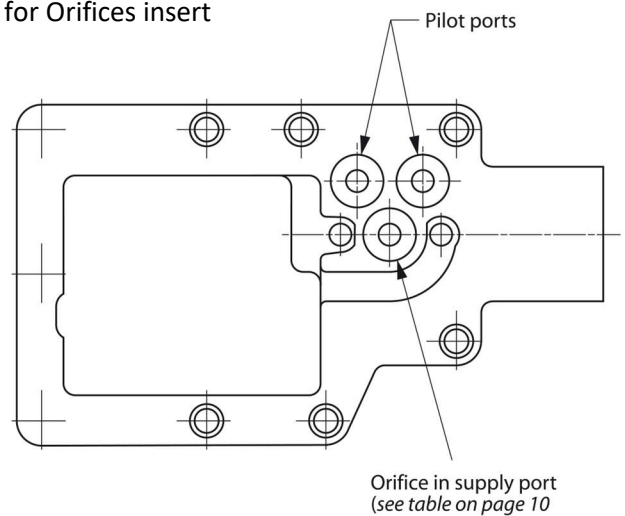

The reversing time in one flow direction can be extended by inserting an orifice in one of the pilot ports only.

Frame size	Diameter of orifice (mm)	Reversing time (s)
20	0,76	3,78
	1,05	2,16
	1,60	1,14
	without orifice	0,60
21	0,76	4,14
	1,05	2,34
	1,60	1,20
	without orifice	0,66
22	0,76	6,06
	1,05	3,42
	1,60	1,74
	without orifice	0,96
23 and 112	0,76	6,24
	1,05	3,54
	1,60	1,80
	without orifice	1,02

Frame size	Diameter of orifice (mm)	Reversing time (s)
24	0,76	10,20
	1,05	5,82
	1,60	2,88
	without orifice	1,68
25	0,76	11,58
	1,05	5,92
	1,60	3,12
	without orifice	1,86
26	0,76	29,70
	1,05	16,20
	1,60	7,50
	without orifice	3,78
27	0,76	30,90
	1,05	15,72
	1,60	7,80
	without orifice	5,64

DIMENSIONS

Table 3: Dimensions (mm)

Frame size	A	A ₁	B	B ₁	B ₂	B ₃	C	D	D ₃	D ₄	D ₅	E	F +0,4	G
20	190	146	47,6	112,7	100	122	56	162	127 ^{0,005}	84	25,4	56	15	163
21	191	146	48	124	110	131						70	15	172
22	194	194	48	133	113	135						83	15	172
23 and 112	194	194	49	150,8	123,8	146						90	15	190,4
24	213	204	70	167	132	153	75	229	152,4	98	25,4	133	21,3	213
25	286	254	80	174	142	162	77	317,5	165,1	98		160	21,3	260
26	285	240	81	197	153	174		317,5	165,1	110		180	21,3	287,4
27	300	274	86	212	172	193		350	177,8	114		208	27,7	317,4

Frame size	G1	H	H ₁	H ₂	H ₃	L	L1	L ₂	S	M	N	R ₁	S ₁
20	81,03	340	270	284	352	224	161,2	93,7	19 ^{-0,25}	94,7	55,6	68	100
21	86	358	282	301	367	246	174	106		108,7	65	68	107
22	86	381	311	314	381	256	188	119		112,7	68,3	68,3	111
23 and 112	95,2	395	320	327	395	270	194	127		127,6	77,8	68,3	117
24	106,5	498	377	412	510	318	239	169		146	87,3	76	148
25	130	560	423	457	560	366	264	196		153,7	97	76	171
26	143,7	584	451	486	614	388	283	215		170,3	108	76	162
27	158,7	656	475	578	656	433	311	244		187,2	127	76	198

Frame size	T	U	V	V ₁	V ₃	X	Y	Z	W	d	d ₁	f
20	9,4 ^{+0,2}	19	152	113	115,9	159	3	3	3/8-16 UNC-2B	34,5 ^{-0,17}	M10-5 H	16
21			160	122	128,6	152	6,35	6,35				
22			165	123	128,6	146	9,5	9,5				
23 and 112			171	134	139,8	140	12,7	12,7		37,68 ^{-0,18}		17,5
24		21	186	154	152,3	173	14	14	5/8-11 UNC-2B	44,03	M14-5 H	23,5
25			199	175	165,1	219	16	16				
26			201	214	167,4	235	14,3	16,3				
27			225	216	190,5	246	17,5	17,5		64,66		M16

Frame size	e	h1	h2	k	l	l1	α	m	n	
20	6,73	62	51,16	48	12,5	min20	45°	52,4	26,2	H – with charge pump: 12-18 cm ³ (sizes 20-23), 33 cm ³ (size 25) H3 – with charge pump: 18 cm ³ (sizes 20-23) 33 cm ³ (size 24) 66 cm ³ (size 25)
21		68	54							
22		71,4	60,5							
23 and 112		77,7	65							
24		88,5	68,2	67	12,45	30				
25		98	74		30					
26		100	79,4		36,7					
27		116	95,3		30					

Frame size	Port A and B	P _{1,2} drain	Port R gear pump	M ₁ , M ₂ , Z ₁
20 - 24	SAE flange, 5000 psi 4 threads, 3/8"-16 UNC-2B, 18 deep	7/8 - 14 UNF-2B	7/8 - 14 UNF-2B	7/16-20 UNF-2B SAE straight thread „O“ ring boss
25	SAE flange, size 1 ^{1/2} " 4 threads, 6000 psi, 5/8-11 UNC-2B, 35 deep	1 ^{5/16} - 12 UN-2B	1 ^{5/16} - 12 UN-2B	
26		1 ^{7/8} - 12 UNF-2B SAE straight threads „O“ ring boss	1 ^{5/16} - 12 UN-2B	
27		SAE flange, size 1 ^{1/4} 3000 psi, 4 threads 7/16-14 UNC-2B		

Figure 8: Outline drawing for axial piston variable displacement pumps Series 20, frame size 20-23.

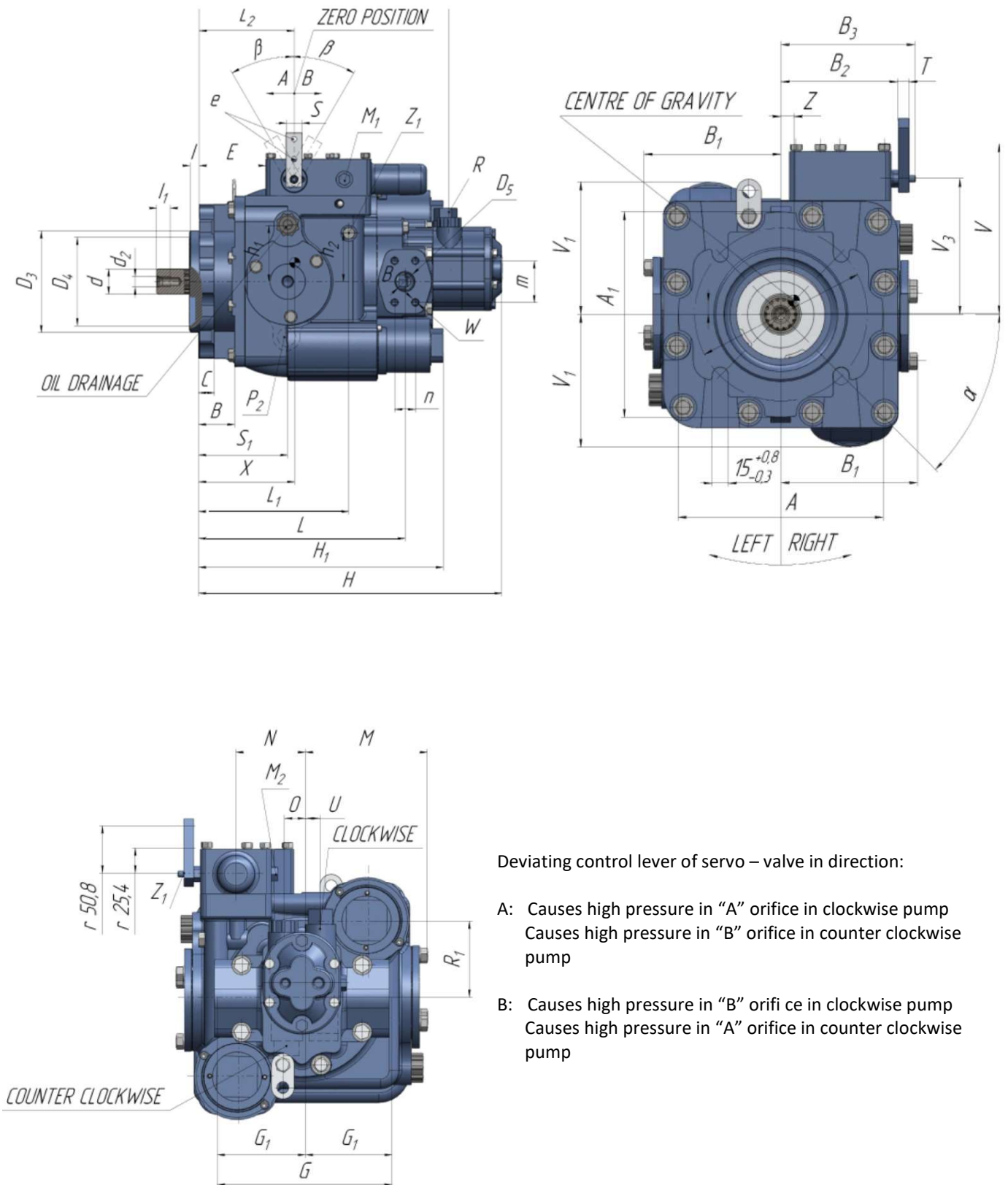
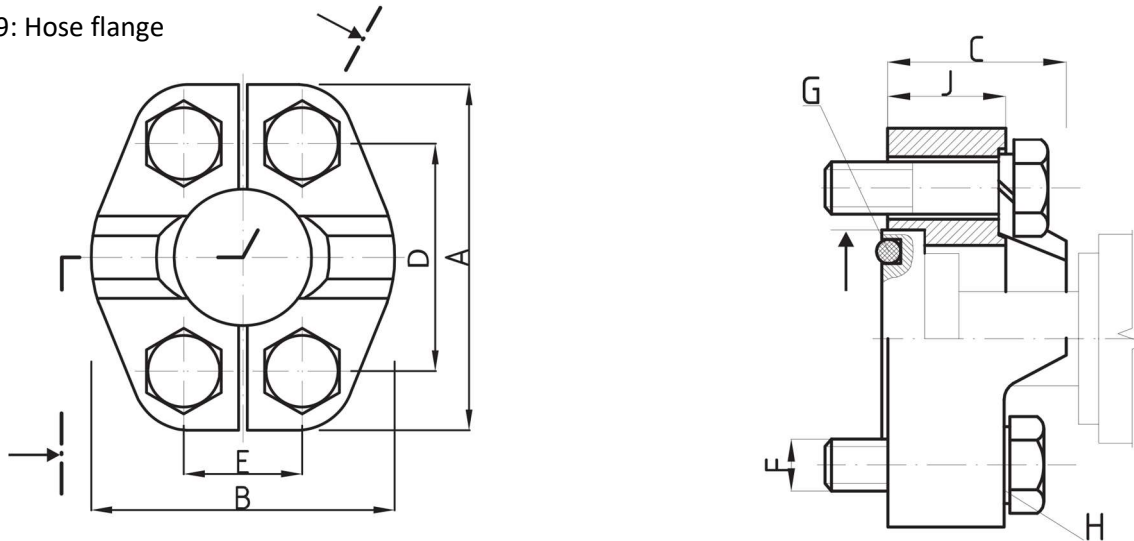

Figure 9: Hose flange



Dimensions (mm)

Frame size	PSI	A	B	C	D-0,1	E-0,1	F	H	J
20-24	5.000 PSI (code B)	81	70	35	52,40	26,20	3/8-16 UNC-2A	Washer 10,20	22,50
20-24	6.000 PSI (code A)	81	70	35	56,37	27,94	7/16-14 UNC-2B	Washer 13,20	22,50
25-27	6.000 PSI	112	95	46	79,40	36,50	5/8-11 UNC-2A	Washer 16,00	30,00

Pipe flange

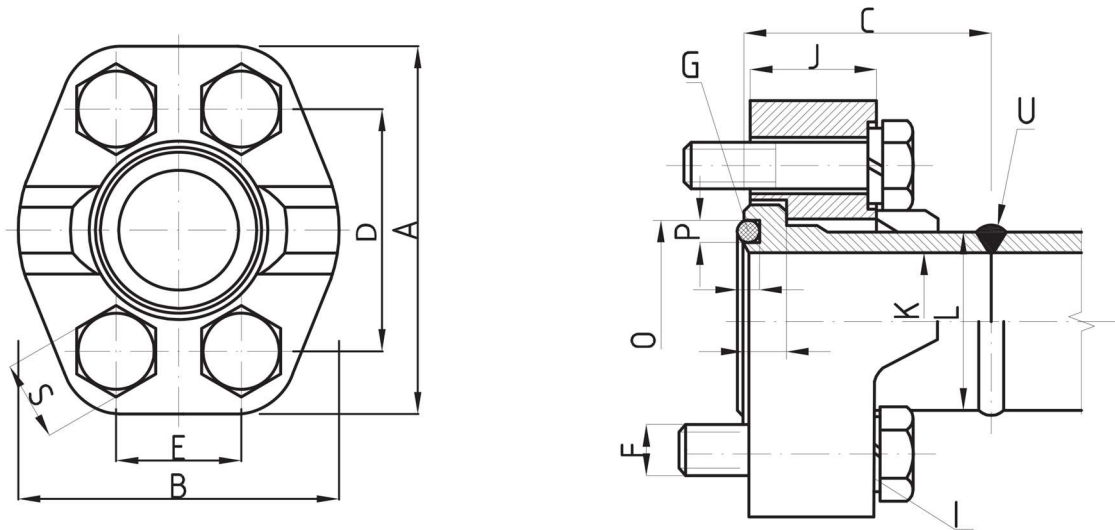

Dimensions (mm)

Frame size	PSI	A	B	C	D-0,1	E-0,1	F	H	J
20-24	5.000 PSI (code B)	81	70	40	52,40	26,20	3/8-16 UNC-2A	Washer 10,00	22,50
20-24	6.000 PSI (code A)	81	70	35	56,37	27,94	7/16-14 UNC-2B	Washer 13,20	22,50
25-27	6.000 PSI	112	95	46	79,40	36,50	5/8-11 UNC-2A	Washer 16,00	30,00

Frame size	PSI	K	L	M-0,1	N-0,1	O	P+0,2	U
20-24	5.000 PSI (code B)	28	38	8,00	2,80	39,7 ± 0,05	4	V5-104
20-24	6.000 PSI (code A)	28	38	8,00	2,80	39,7 ± 0,05	4	V5-104
25-27	6.000 PSI	38	50	12,60	2,80	53,9 ± 0,01	4	V6-158

Note:

Flange according to SAE J 518 c

Frame size 20 – 24: size 1, 5000 psi, torque for screw tightening 3/8 – 16 UNC2A: 37 – 42 Nm

Frame size 25 – 27: size 1 1/2, 6000 psi, torque for screw tightening 5/8 – 11 UNC2A: 158 – 181 Nm

Input shaft details for sizes 20,21,22,23 and 112

Teeth splined shafts

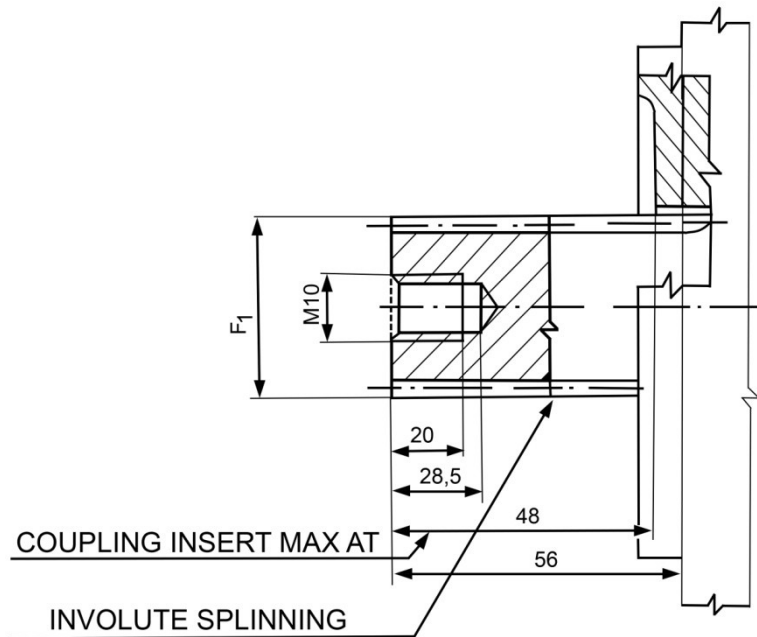

Profile angle – 30°

 F_2 - pitch

 F_3 - number of teeth

 F_4 - teeth modul

Shaft type	Size available	Dimensions			
		F_1	F_2	F_3	F_4
A	20,21,22,23	31,22	29,634	14	12/24
B	20,21,22,23	31,75	30,163	19	16/32
C	20,21,22,23	34,5	33,338	21	16/32
D	23	37,68	36,512	23	16/32
E	23	44,03	42,863	27	16/32
G	23	43,71	41,275	13	8/16
I	20,21,22,23	32,91	31,75	20	16/32

Type K (Tapered key shaft, cone 1:8)

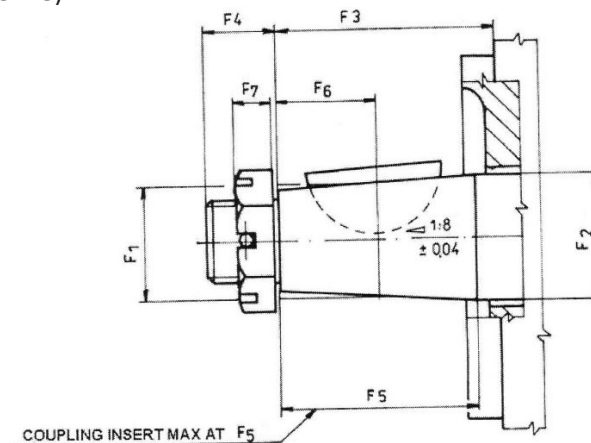

Shaft type	Size	F_1	F_2	F_3	F_4	F_5	F_6	F_7
K	20,21,22,23	31,75	34,94	57,3	19,1	47,8	22,4	12,7
J	23	41,275	44,45	66,5	22,1	53,8	28,45	15,7

AXIAL PISTON VARIABLE PUMP PV24

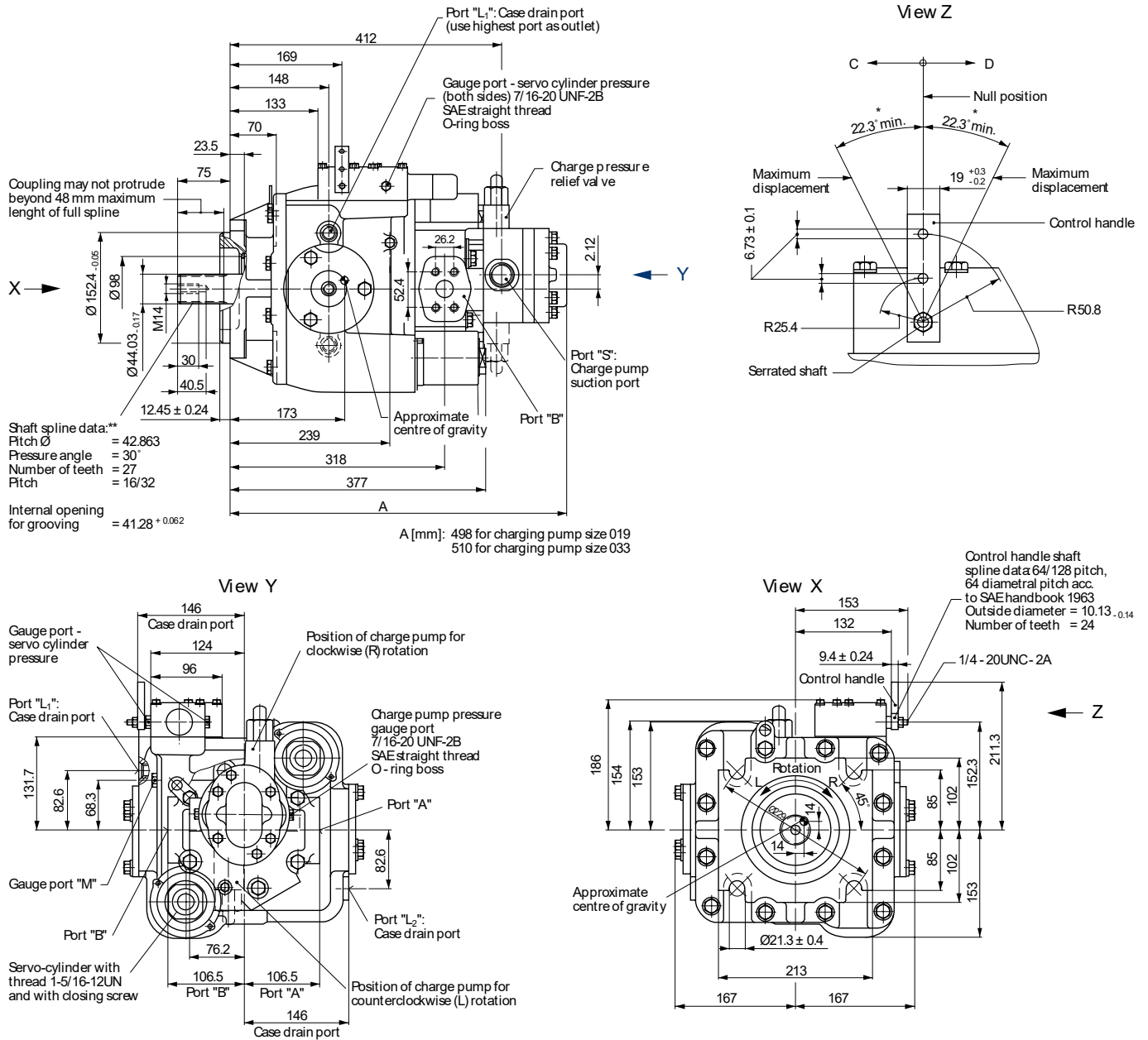

Frame size	Port A and B	Port L ₁ and L ₂	Port S	Port M	Input Shafts
119 cm ³	SAE flange, size 1 SAE split flange boss 5000 psi, 4 threads 3/8-16 UNC-2B 18 deep	7/8-14 UNF-2B SAE straight thread O-ring boss	1 5/16-12 UNF-2B SAE straight thread O-ring boss	7/16-20 UNF-2B SAE straight thread O-ring boss	13 teeth 27 teeth Cylindrical

Notice – PV24 displacement can be increased to 125,0 cm³

AXIAL PISTON VARIABLE PUMP PV25

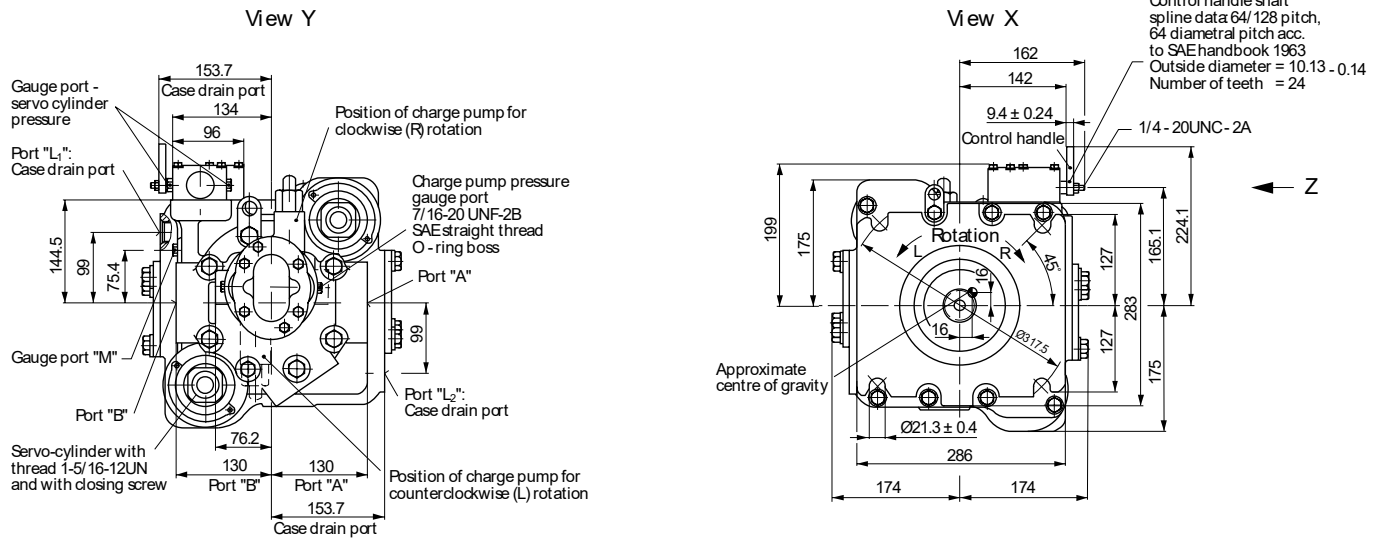
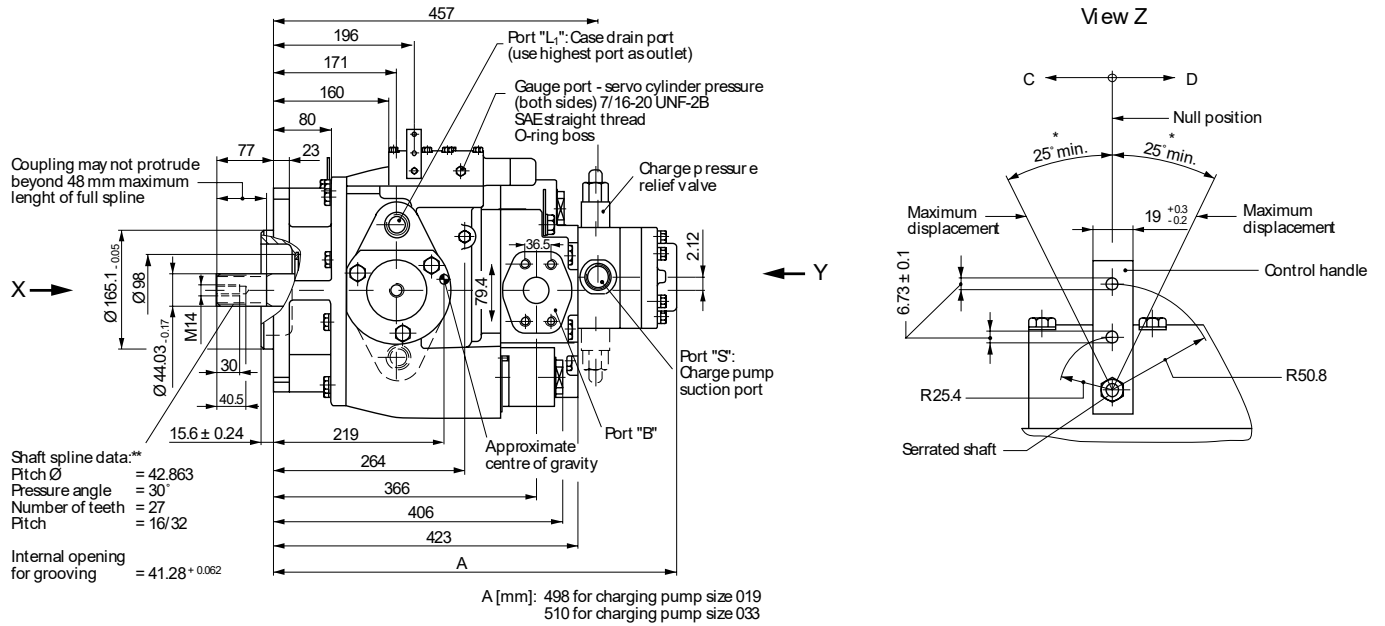

Frame size	Port A and B	Port L ₁ and L ₂	Port S	Port M	Input Shafts
166 cm ³	SAE flange, size 1 1/2 SAE split flange boss 6000 psi, 4 threads 5/8-11 UNC-2B 35 deep	1 5/16-12 UNF-2B SAE straight thread O-ring boss	1 5/16-12 UNF-2B SAE straight thread O-ring boss	7/16-20 UNF-2B SAE straight thread O-ring boss	13 teeth 27 teeth Cylindrical

AXIAL PISTON VARIABLE PUMP PV26

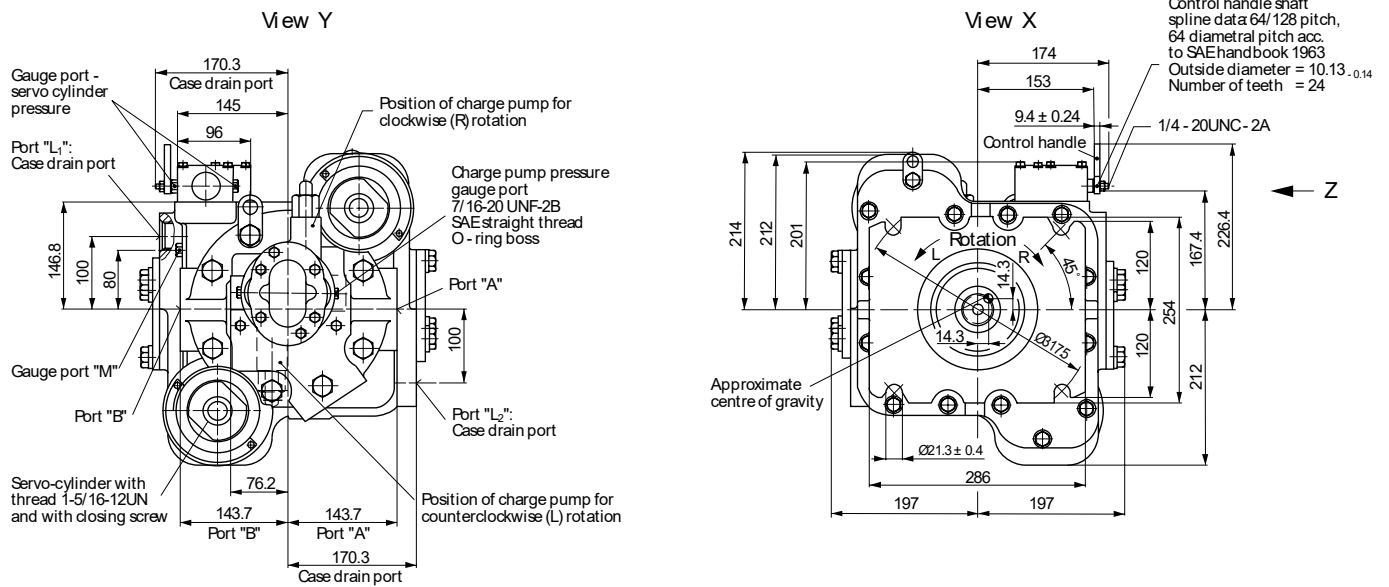
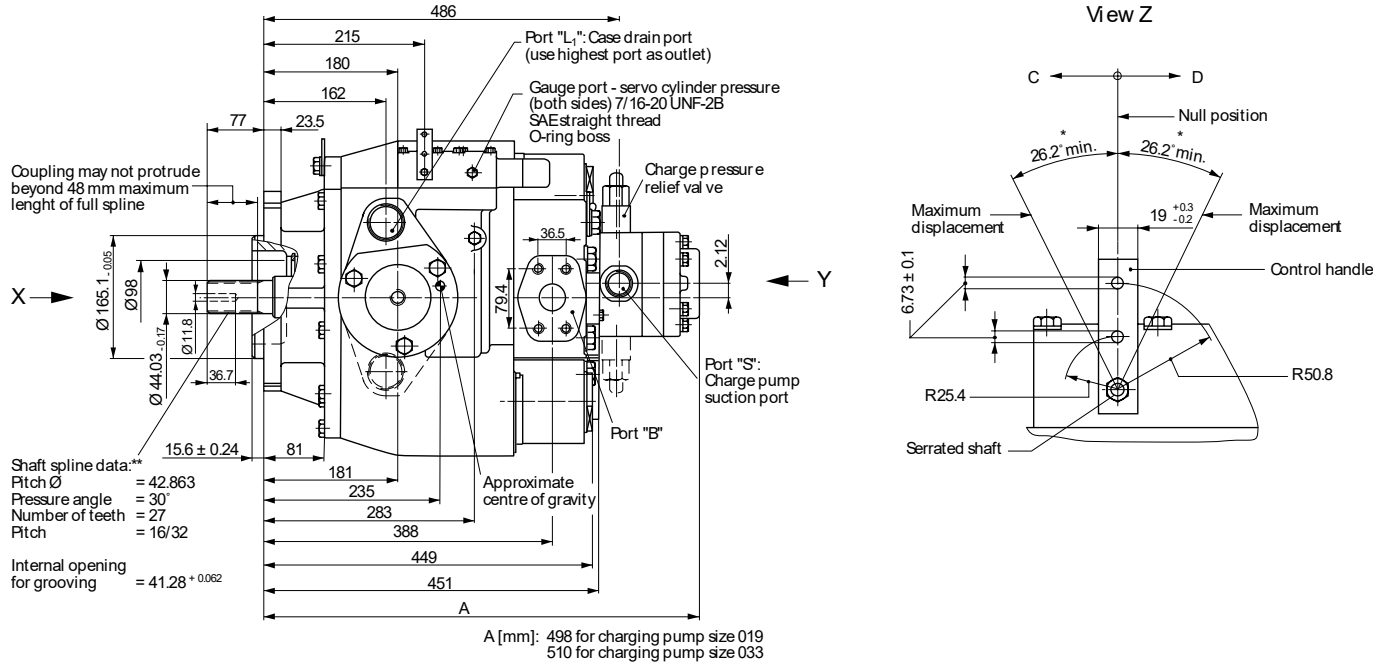

Frame size	Port A and B	Port L ₁ and L ₂	Port S	Port M	Input Shafts
227 cm ³	SAE flange, size 1 1/2 SAE split flange boss 6000 psi, 4 threads 5/8-14 UNC-2B 35 deep	1 7/8-12 UNF-2B SAE straight thread O-ring boss	1 5/16-12 UNF-2B SAE straight thread O-ring boss	7/16-20 UNF-2B SAE straight thread O-ring boss	13 teeth 27 teeth Cylindrical

AXIAL PISTON VARIABLE PUMP PV27

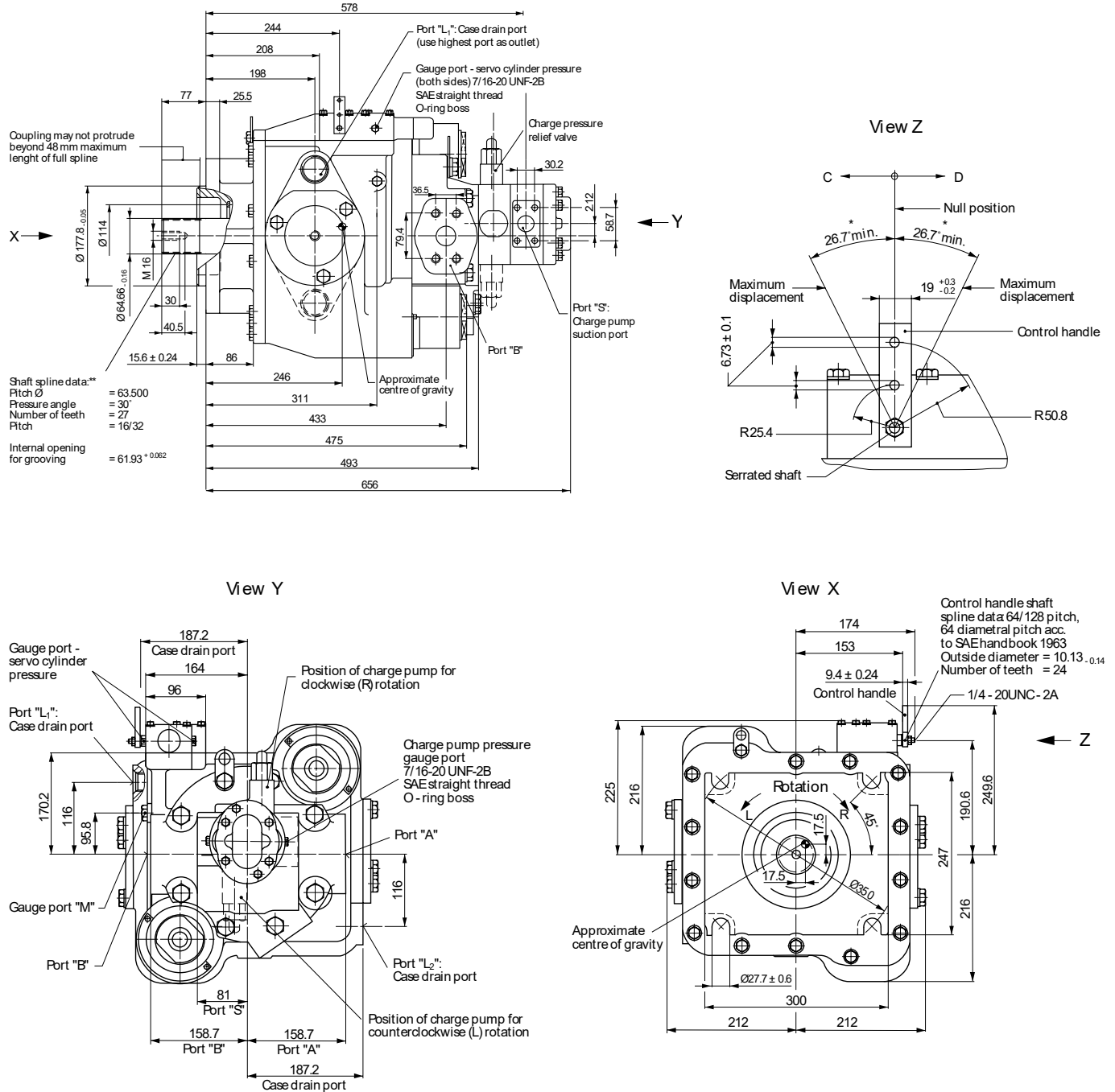

Frame size	Port A and B	Port L ₁ and L ₂	Port S	Port M	Input Shafts
334 cm ³	SAE flange, size 1 1/2 SAE split flange boss 6000 psi, 4 threads 5/8-11 UNC-2B 35 deep	1 7/8-12 UNF-2B SAE straight thread O-ring boss	SAE flange, size 1 1/4 SAE split flange boss 3000 psi, 4 threads 7/16-14 UNC-2B 28 deep	7/16-20 UNF-2B SAE straight thread O-ring boss	15 teeth 40 teeth Cylindrical

TYPE DESIGNATION

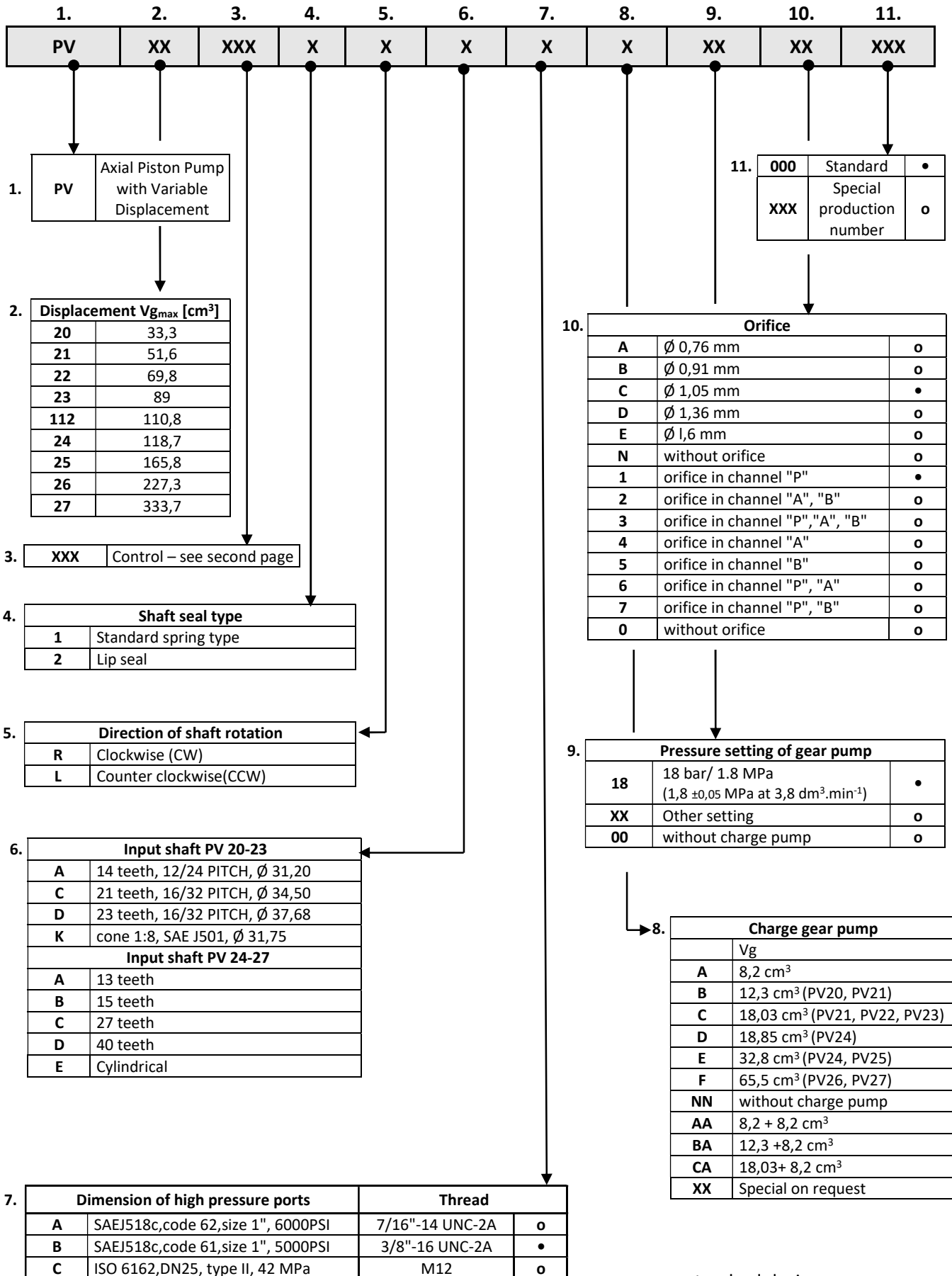

- standard design
- o available

TYPES OF CONTROLS

WITHOUT CONTROL DEVICE

AAA	with top cover only
------------	---------------------

MECHANICAL-HYDRAULIC

MH	mechanical-hydraulic servovalve
MC	mechanical-hydraulic servovalve with a pressure override valve (POR)

ELECTRO-HYDRAULIC

EPxx	Proportional electric valve
12	electric control; voltage 12 V
24	electric control; voltage 24 V
ERx	three-positional distributor
1	electric control; voltage 12 V, D _n 6mm
2	electric control; voltage 24 V, D _n 6mm
3	electric control; voltage 12 V, D _n 4mm
4	electric control; voltage 24 V, D _n 4mm
MCV	MCV 116 proportional control

HYDRAULIC

PH	direct hydraulic control (joystick)
HDC	hydraulic proportional control (HDC hydraulic valve)
HDC POR	hydraulic proportional control with POR valve

Ordering examples :

PV23 MH 2 R D B C 18 C1 000

Type of pump – **PV23**

Control – **MH** - mechanical servovale

Shaft seal type – **2** - lip seal

Rotation – **R** – CW, (right)

Shaft – **D** – splined type, 23 teeth

High pressure port – **B** - 5000 psi

Charge pump – **C** - gear pump 18,05 cm³

Charge pump pressure setting – **18** - 18 bar

Orifice – **C1** - 1,05 mm in channel P

Special – **000** – none

PV27 MH R 1 D A F 18 C1 000

Type of pump – **PV27**

Control – **MH** - mechanical servovale

Shaft seal type – **1** – standard mechanical seal

Rotation – **R** – CW, (right)

Shaft – **D** – 40 teeth splined type

High pressure port – **A** - 6000 psi

Charge pump – **F** - 65,5 cm³

Charge pump pressure setting – **18** - 18 bar

Orifice – **C1** - 1,05 mm in channel P

Special – **000** – none

Axial piston variable displacement pumps **PVS series (short version)** are developed from classic 20 series SPV pumps using gerotor type charge pump and thru drive for connecting with additional gear pumps or tandems.

Basic dimensions :

Frame size	Dimensions (mm)										
	L	L ₁	L ₂	L ₃	L ₄	L ₅	L ₆	L ₇	L ₈	L ₉	L ₁₀
PVS 22	356	311	259	111	119	48	16	327	71,4	68	85,8
PVS 23	364	320	270	118	127	49	17,5	335	77,8	77,8	95,25
PVS 112											

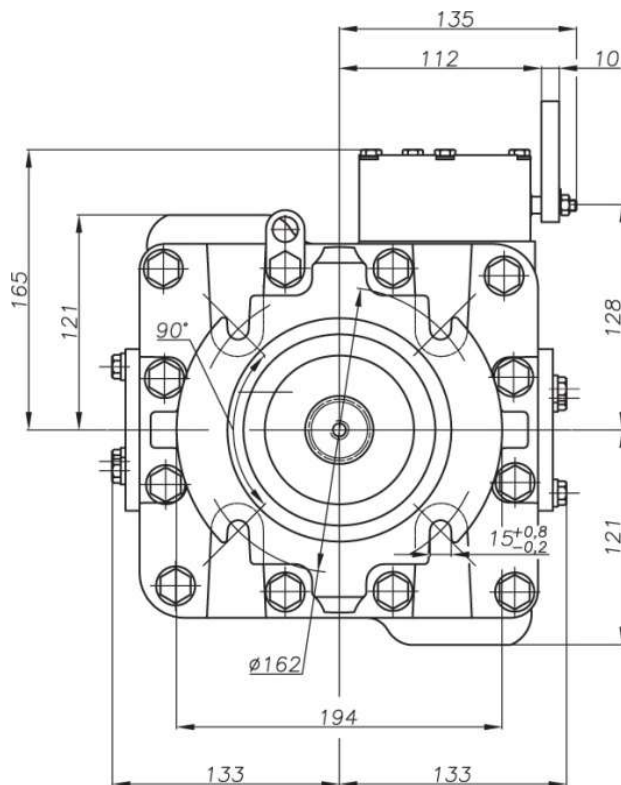
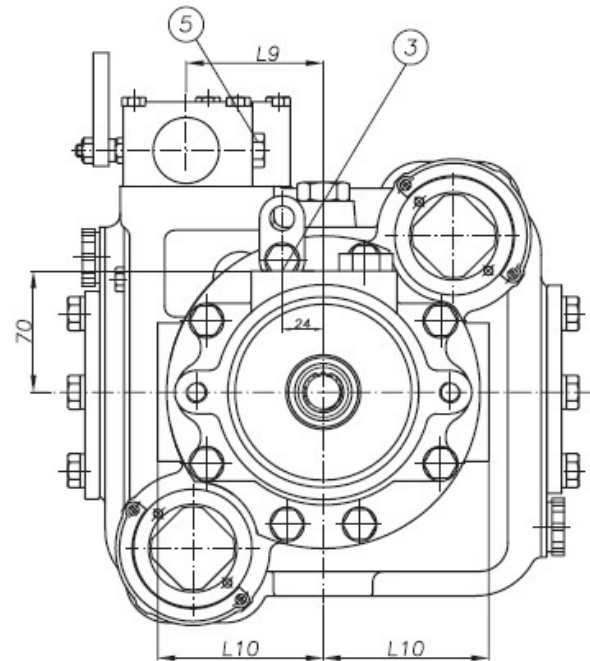
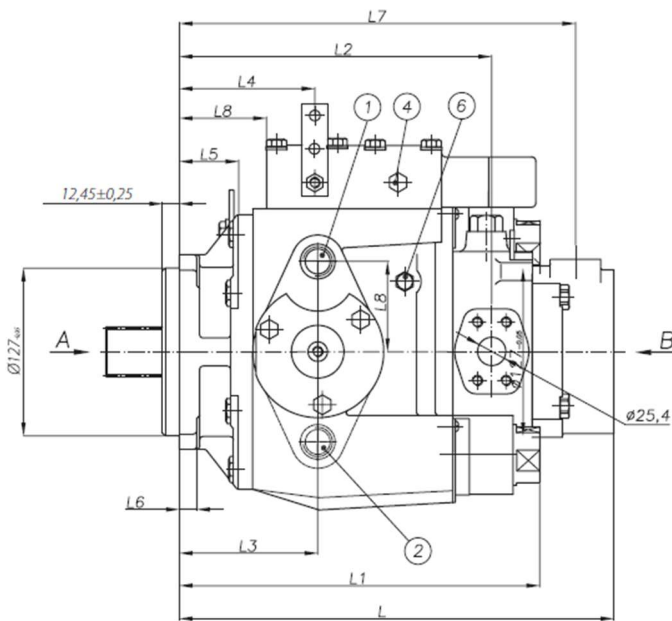

PVS 22

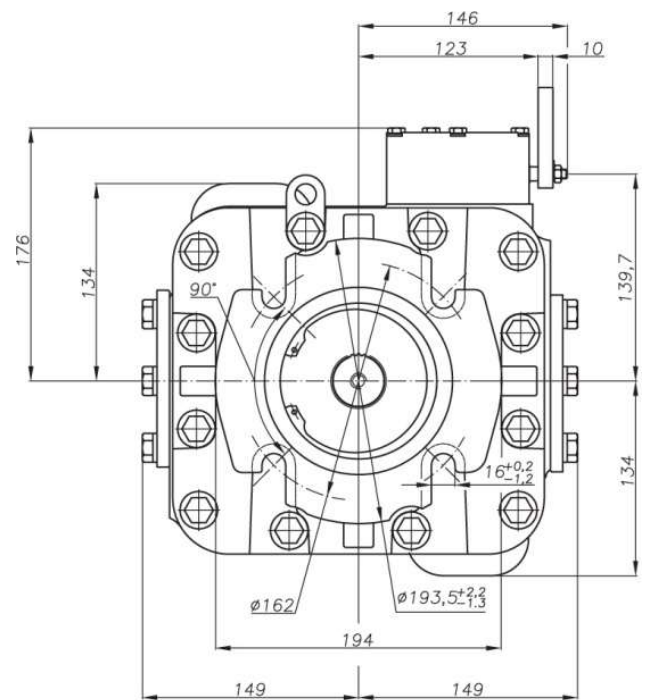

Right Hand Rotation ← → Left Hand Rotation

PVS 23, PVS 112

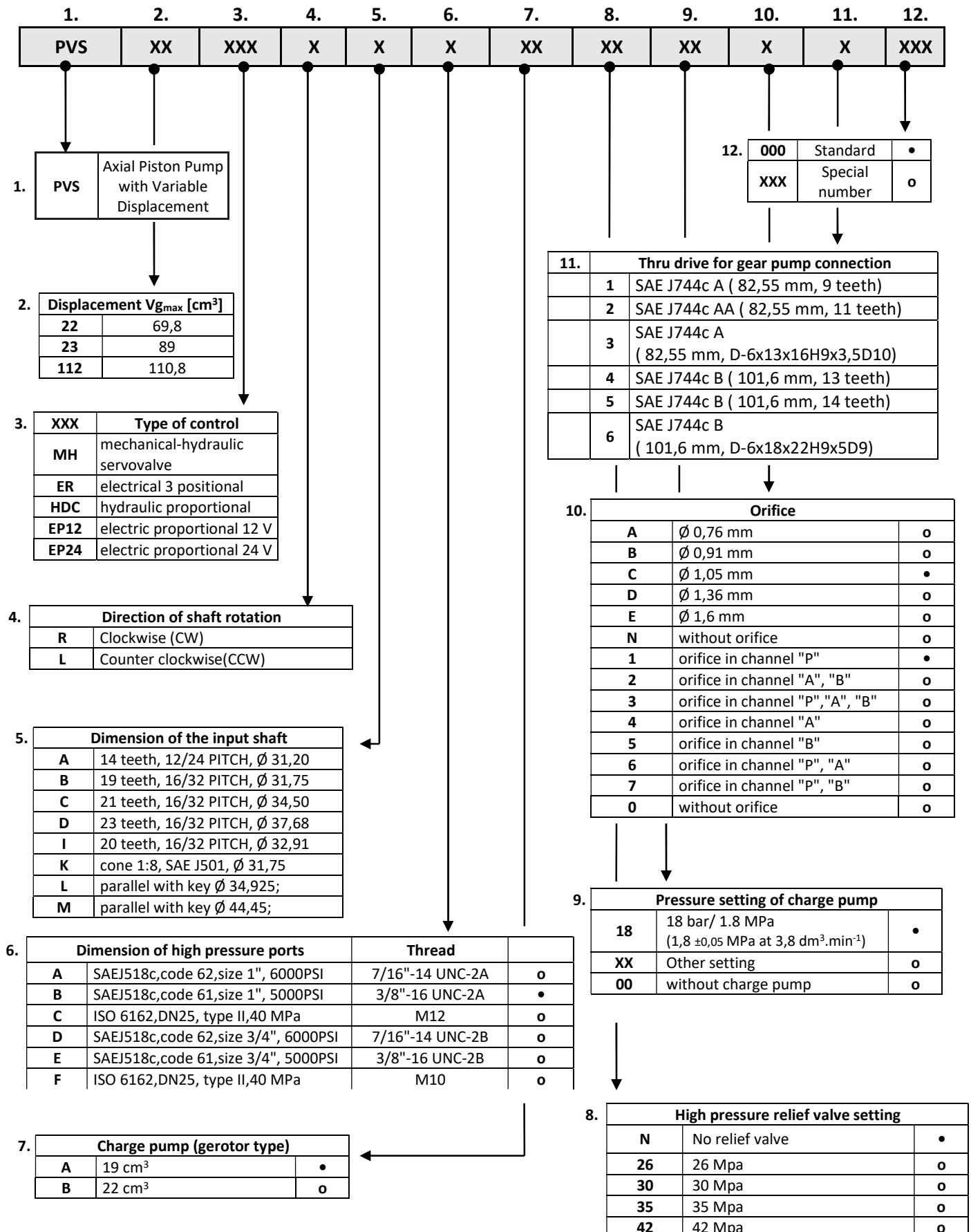
PVS (short pump with thru drive) - TYPE DESIGNATION

- standard design
- o available

Ordering example :
PVS 23 MH R D B A N 18 C1 4 000

 Type of pump – PVS 23 (displacement 89 cm³)

Control – MH (mechanical servovalve)

Rotation – R (right)

Shaft – D (splined, 23 teeth)

High pressure port – B (5000 psi)

 Charge pump – A (gerotor type 19 cm³)

High pressure relief valve – N (no relief valve)

Charge pump pressure setting – 18 (18 bar)

Orifice – C1 (1,05 mm in channel P)

Thru drive for gear pump connection – 4 (13 teeth, SAE B)

Special – 000 (none)

Mounting Dimensions for Gear Pumps

Code	Connect. type	Teeth no.	Dimensions (mm)									
			D _a	M	d	b	D ₁	D ₂	L	L ₁	D ₄	L ₂
1	SAE A	9	12,926 ^{+0.11}	-	-	-	82,57 ^{+0.04}	91 ^{+0.22}	106,4	7,5	M10-7H	15min
2	SAE AA	11	16,017 ^{+0.11}	-	-	-	82,57 ^{+0.04}	91 ^{+0.22}	106,4	7,5	M10-7H	15min
3	SAE J744c A	-	-	D 6x13x16H9x3.5D10	13 ^{+0.11}	3,5 ^{+0.078}	-	-	-	-	-	-
4	SAE B	13	19,133 ^{+0.11}	-	-	-	101,62 ^{+0.04}	110 ^{+0.22}	146,1	10	M12-7H	25min
5	SAE B	14	28 ^{+0.13}	-	-	-	101,62 ^{+0.04}	110 ^{+0.22}	146,1	10	M12-7H	25min
6	SAE J744cB	-	-	D 6x18x22H9x5D9	18 ^{+0.11}	5 ^{+0.078}	101,62 ^{+0.04}	110 ^{+0.22}	146,1	10	M12-7H	25min

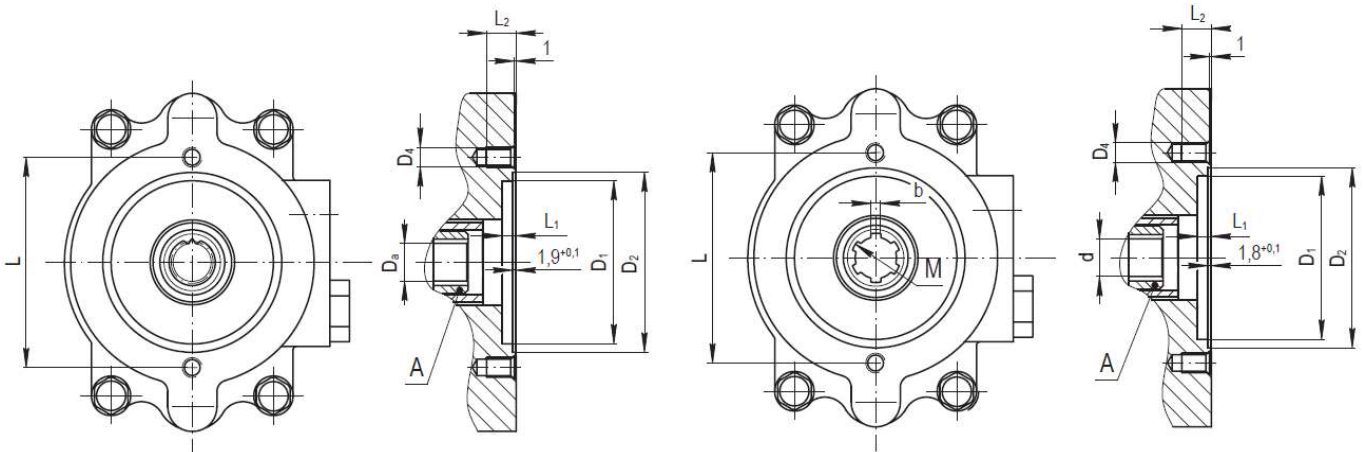

Drain port size	Ports	
	1, 2, 3	4, 5, 6
all PVS sizes	7/8-14 UNF-2B	7/16-20 UNF-2B

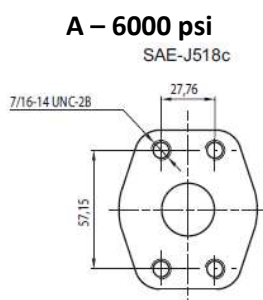
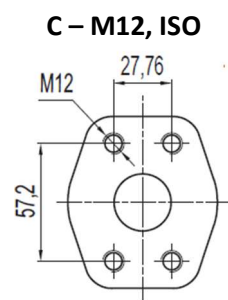
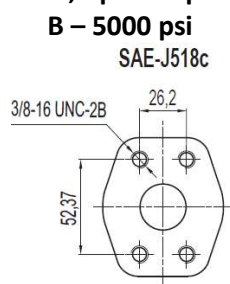

Main A,B ports options

Tandem pumps PVS – are designed from standard 20 series, connected together into tandem version with special intermediate piece and using gerotor charge pumps.

Second stage can be equipped with thru drive (SAE-A or SAE-B) for gear pump connection.

Available in sizes - 23 and 112 with combinations 23-23, 23-112, 112-112, 112-23.

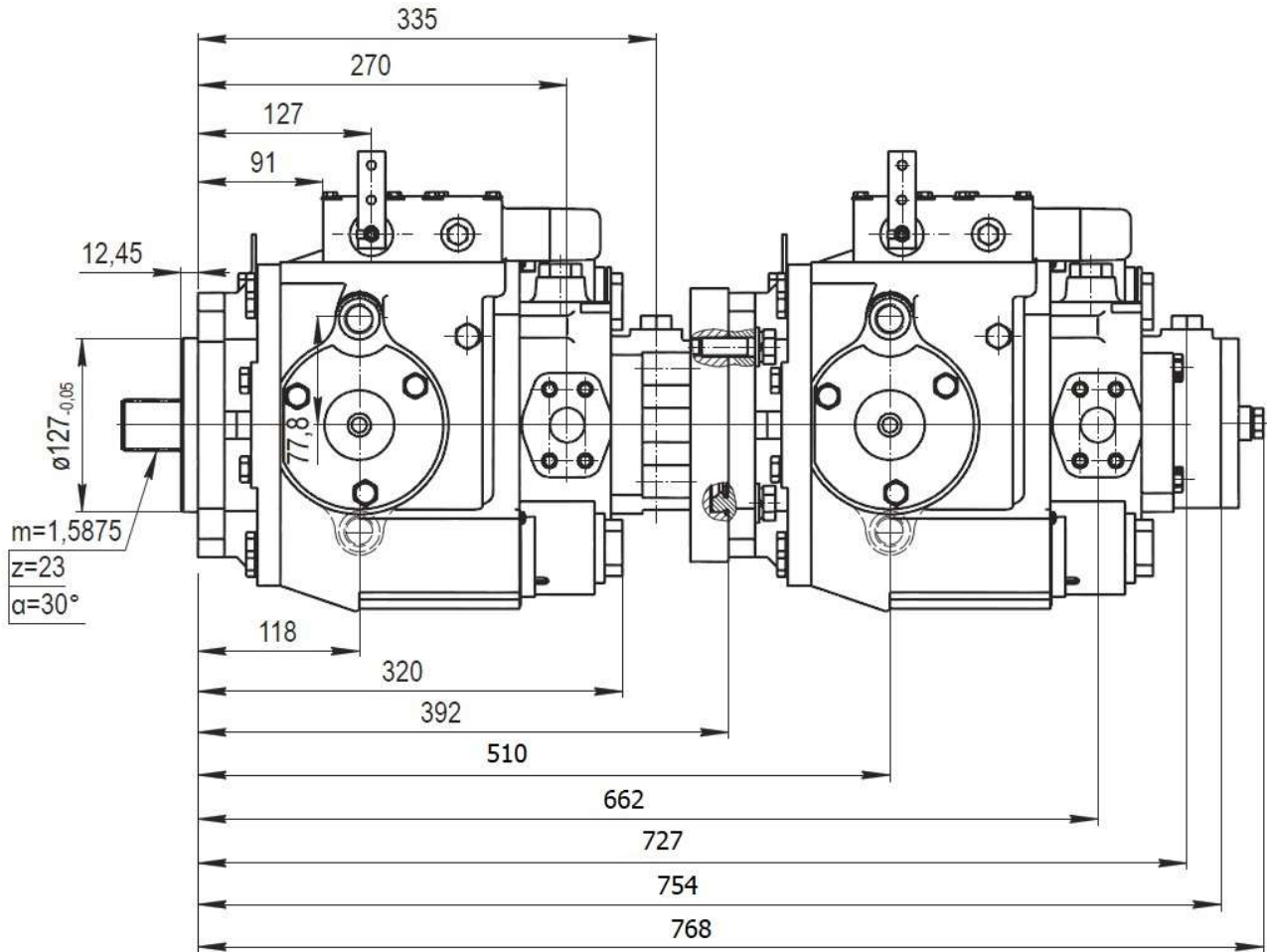
Dimensions :



Mounting dimensions for tandem connection

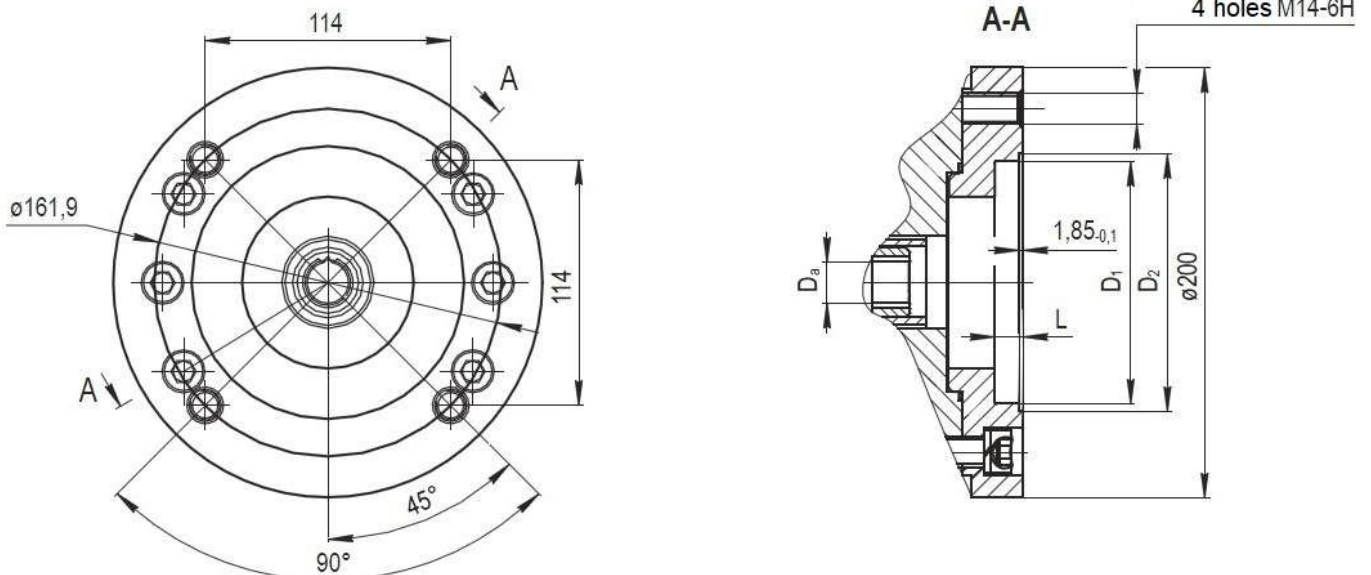

Ordering codes for each stage are identical with our PVS model code.

SPARE PARTS FOR PV pumps

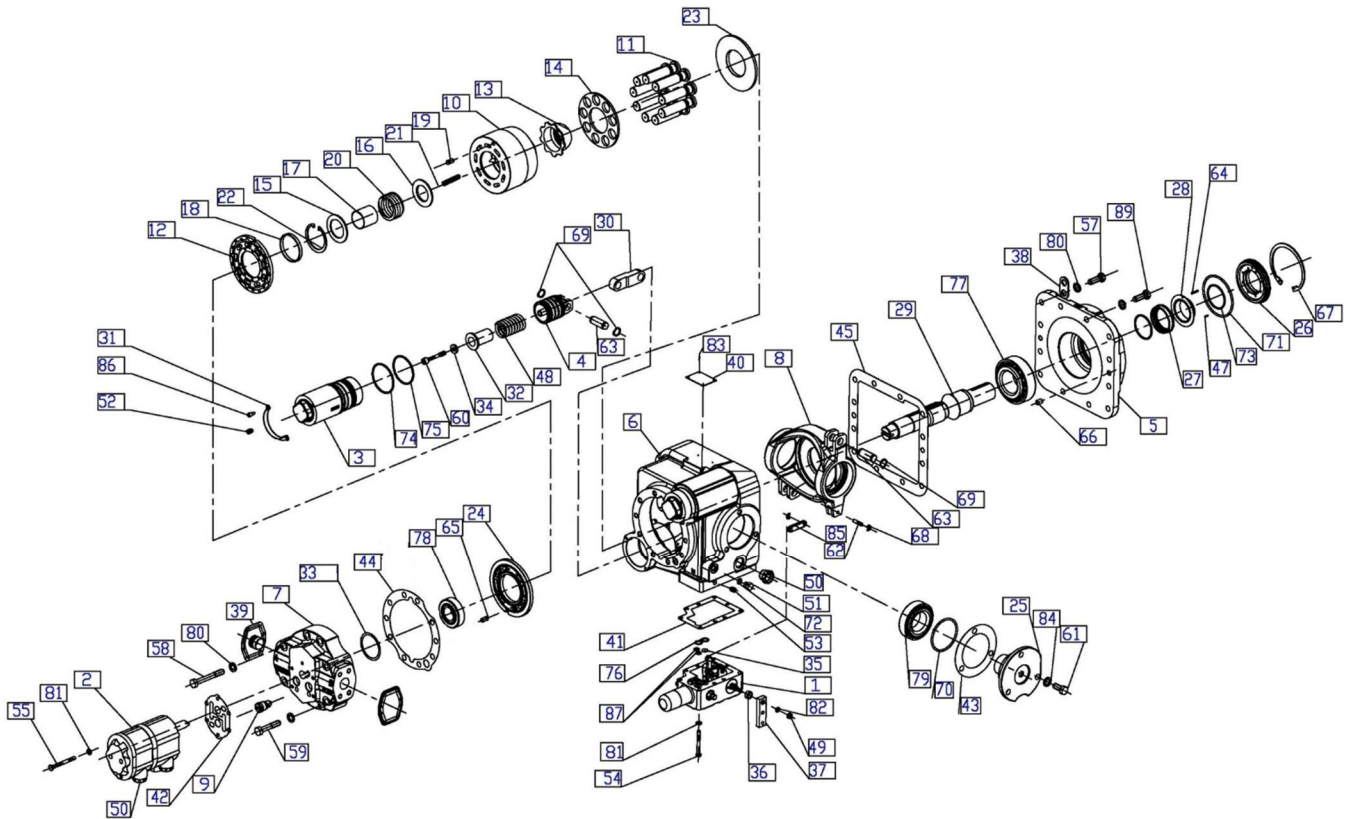

Item	Pcs	Name	Item	Pcs	Name	Item	Pcs	Name
1	1	Servo valve Assembly	31	2	Sleeve Retainer	63	4	Pin
2	1	Charge Pump CW, CCW	32	2	Spring Guide	64	1	Shaft seal Drive Screw
3	2	Servo Cylinder	33	1	Shim	65	1	Rear Cover Pin
4	2	Servo Piston	34	2	Washer	66	4	Pin
5	1	Front Cover	35	1	Orifice	67	1	Shaft Seal Retaining Ring
6	1	Pump Housing	36	1	Spacer	68	2	Swashplate Pin Retaining Ring
7	1	End Cap	37	1	Control Handle	69	8	Swashplate Pin Retaining Ring
8	1	Swash Plate	38	3	Loop	70	2	Trunnion O-Ring
9	2	Check Valve	39	2	Cap	71	1	Shaft Seal O-Ring
10	1	Cylinder Barrel Housing	40	1	Brand plate	72	1	O-Ring
11	9	Piston Assembly	41	1	Control Valve Gasket	73	2	Shaft Seal O-Ring
12	1	Bearing Plate	42	1	Charge Pump Gasket	74	2	Servocylinder O-Ring
13	1	Retainer Guide	43	2	Trunnion Shim	75	2	Servocylinder O-Ring
14	1	Slipper Retainer	44	1	End Cap Gasket	76	3	Control Valve O-Ring
15	1	Spring Retainer	45	1	Front cover Gasket	77	1	Main shaft bearing
16	1	Spring Seat	47	6/8	Shaft Seal Seal Spring	78	1	Shaft bearing
17	1	Spring Guide	48	2	Servo Spring	79	2	Swashplate bearing
18	1	Bearing Plate Pilot	49	1	Control Handle Nut	80	20	Washer
19	1	Pin	50	3	Plastic Plug	81	13	Washer
20	1	Cylinder Barrel Spring	51	1	Plug	82	1	Control Handle Washer
21	6	Retainer Spring	52	4	Expander 05	83	4	Drive Screw
22	1	Retaining Ring	53	1	Expander 09	84	6	Washer
23	1	Thrust Plate	54	9	Hex Head Screw	85	1	Link Swahsplate
24	1	Valve Plate CW, CCW	55	4	Charge Pump Screw	86	4	Socket Head Screw
25	2	Trunnion	57	8	Hex Head Screw	87	2	Aluminium ring
26	1	Seal Retainer	58	3	End Cap Screw	89	4	Hex Head Screw
27	1	Rotating Seal	59	5	End Cap Screw			
28	1	Stationary Seal	60	2	Screw	set	1	Cylinder barrel set
29	1	Drive Shaft	61	6	Hex Head Screw	set	1	Set of gaskets
30	2	Servo Link	62	1	Pin	set	1	Shaft seal kit 26,27,28,47,64,67,71,73

To enquiry for spare parts, please specify the following :
 - position number according to explosion view
 - name of the part
 - size of pump or motor (PV or MF 20, 21, 22, 23, 24, 25, 26, 27)
 - quantity required

SPARE PARTS FOR PVS pumps

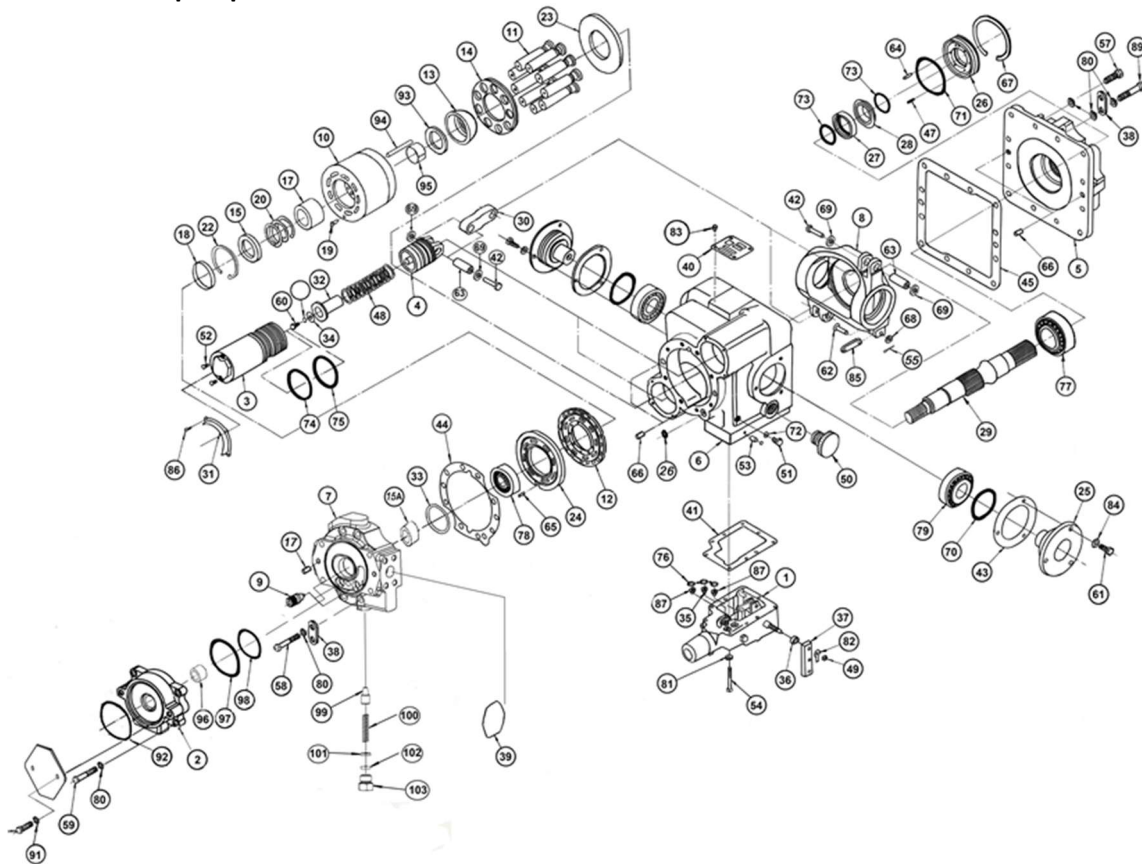

Item	Pcs	Name	Item	Pcs	Name	Item	Pcs	Name
1	1	Servo valve Assembly	35	1	Orifice	71	1	Shaft Seal O-Ring
2	1	Charge Pump CW, CCW	36	1	Spacer	72	1	O-Ring
3	2	Servo Cylinder	37	1	Control Handle	73	2	Shafts Seal O-Ring
4	2	Servo Piston	38	3	Loop	74	2	Servocylinder O-Ring
5	1	Front Cover	39	2	Cap	75	2	Servocylinder O-Ring
6	1	Pump Housing	40	1	Brand plate	76	4	Control Valve O-Ring
7	1	End Cap	41	1	Control Valve Gasket	77	1	Main shaft bearing
8	1	Swash Plate	42	1	Charge Pump Gasket	78	1	Shaft bearing
9	2	Check Valve	43	2	Shim Pack	79	2	Swashplate bearing
10	1	Cylinder Barrel Housing	44	1	End Cap Gasket	80	20	Washer
11	9	Piston Assembly	45	1	Front Cover Gasket	81	13	Washer
12	1	Bearing Plate	47	6/8	Shaft Seal Seal Spring	82	1	Washer
13	1	Retainer Guide	48	2	Servo Spring	83	4	Drive Screw
14	1	Slipper Retainer	49	1	Nut	84	6	Washer
15	1	Spring Retainer	50	3	Plastic Plug	85	1	Link Swahsplate
16	1	Spring Seat	51	1	Plug	86	4	Socket Head Screw
17	1	Spring Guide	52	4	Expander 05	87	2	O-Ring
18	1	Bearing Plate Pilot	53	1	Expander 09	89	4	Hex Head Screw
19	1	Pin	54	9	Hex Head Screw	90	2	Cover Screw
20	1	Cylinder Barrel Spring	55	4	Hex Head Screw	91	2	Cover Washer
21	6	Retainer Spring	57	8	Hex Head Screw	92	1	O ring
22	1	Retaining Ring	58	3	End Cap Screw	93	1	Retainer Guide Washer
23	1	Thrust Plate	59	5	End Cap Screw	94	3	Pin
24	1	Valve Plate CW, CCW	60	2	Screw	95	1	Bush
25	2	Trunnion	61	6	Hex Head Screw	96	1	Bush
26	1	Seal Retainer	62	1	Pin	97	1	O ring
27	1	Rotating Seal	63	4	Pin	98	1	O ring
28	1	Stationary Seal	64	1	Shaft Seal Drive Screw	99	1	Valve
29	1	Drive Shaft	65	1	Rear Cover Pin	100	1	Spring
30	2	Servo Link	66	4	Pin	101	1	Washer
31	2	Sleeve Retainer	67	1	Shaft Seal Retaining Ring	102	1	Ring
32	2	Spring Guide	68	2	Retaining Ring	103	1	Plug
33	1	Shim	69	8	Retaining Ring			
34	2	Washer	70	2	Trunnion O-Ring	set	1	Rotary group assy

MF MOTORS - GENERAL DESCRIPTION

Axial piston fixed displacement motors Series 20 are of swash plate construction and are intended for closed circuit operation. The output speed is responding to the flow rate of the input fluid.

The output torque is proportional to the differential between high and low pressure sides of the fluid circuit.

The direction of motor (output) shaft rotation depends upon which port the fluid enters the motor.

Figure 1:

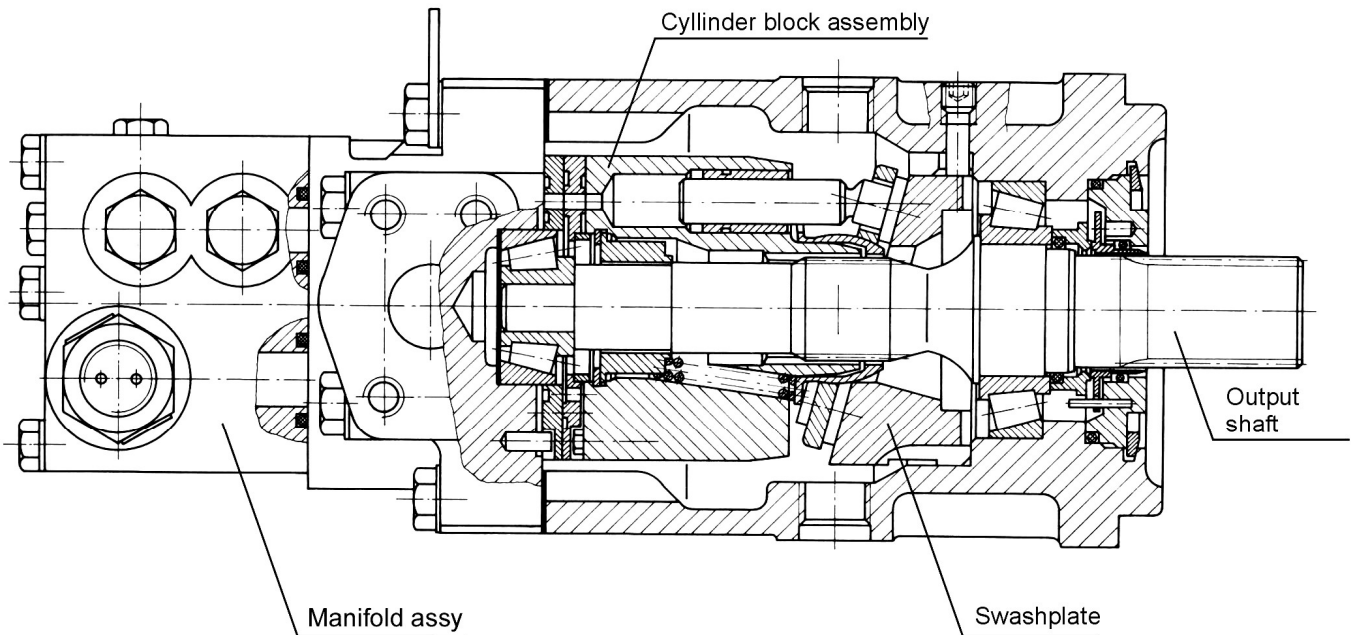
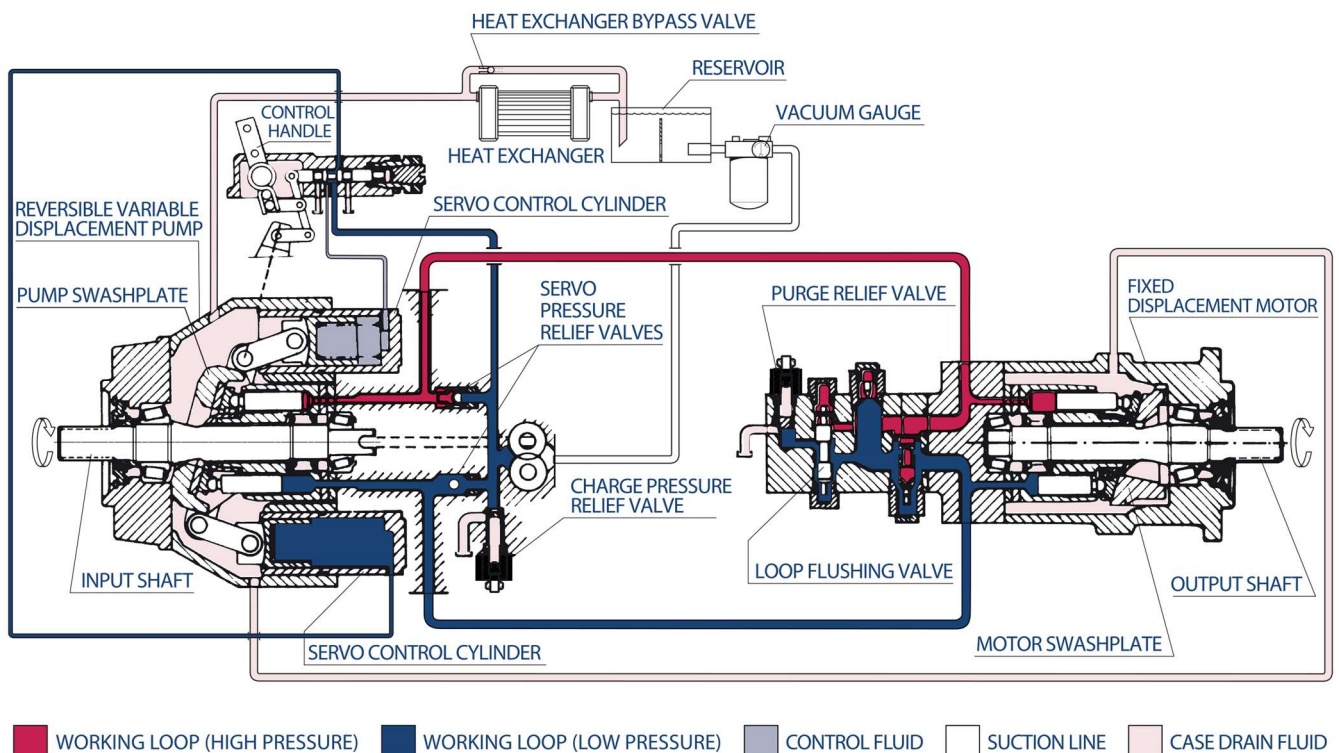

Figure 2 - the function of hydrostatic transmission using axial piston variable displacement pump and fixed displacement motor.



■ WORKING LOOP (HIGH PRESSURE)
 ■ WORKING LOOP (LOW PRESSURE)
 ■ CONTROL FLUID
 SUCTION LINE
 ■ CASE DRAIN FLUID

TECHNICAL DATA

Table 1:

Parameter	Dimension	Frame size																	
		20	21	22	23	112	24	25	26	27									
Max. displacement per revolution	cm ³	33,3	51,6	69,8	89,0	111,0	118,7	165,8	227,3	333,7									
Max. flow	dm ³ min ⁻¹	119,5	160,0	196,1	230,5	277,0	278,9	348,2	429,6	557,3									
Max. torque	Nm	203	314	425	542	675													
Max. pressure	MPa	42																	
Nominal pressure	MPa	21																	
Max. pressure of control	MPa	3,5																	
Max. pressure in case	MPa	0,25 continuous 0,5 intermittent																	
Maximum speed +	min ⁻¹	3590	3100	2810	2600	2600	2350	2100	1890	1670									
Minimum speed	min ⁻¹	500																	
Nominal speed	min ⁻¹	1500																	
Kinematic viscosity range of working fluid	mm ² s ⁻¹																		
-starting											1000								
-operating											12-600								
-optimum	25-35																		
Kind of working fluid		mineral oil																	
Operating outside temperature	°C	-40 to +50																	
Max. temperature of working fluid in tank	°C	80																	
Purity of working fluid	µm	10																	
Direction of shaft rotation		reversible																	
Maximum swash plate angle	°	±18°																	
Weight	kg	30	35	40	47	50	70	124	152	197									

+ for higher speeds contact our Application department

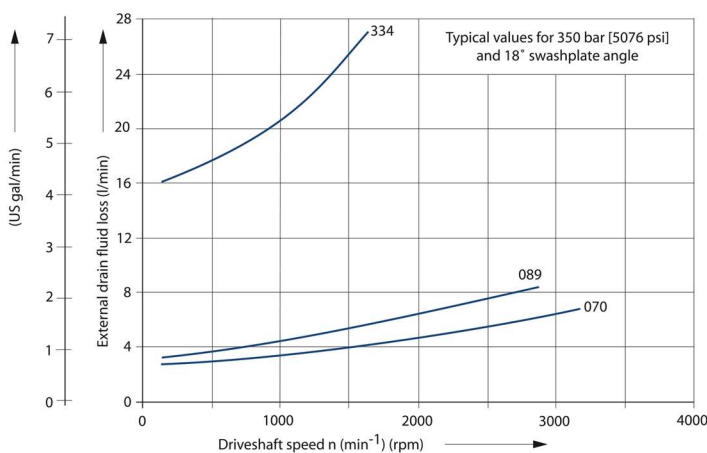
 Figure 3. External drain fluid loss for frame sizes 20 – 23
 Determination of nominal pump size

$$Q_e = \frac{V_g \cdot n \cdot \eta_v}{1000} \text{ (l/min) Motor input flow}$$

$$M_e = \frac{15,9 \cdot V_M \cdot \Delta p \cdot \eta_{mh}}{100} \text{ (Nm) output torque}$$

$$P_e = \frac{M_g \cdot n}{9550} = \frac{Q_e \cdot \Delta p \cdot \eta_t}{600} \text{ (kW) output power}$$

V_M - displacement (cm³) per revolution
 Δp - difference high and low pressure (MPa)
 n - speed (min⁻¹)
 η_v - volumetric efficiency
 η_{mh} - mechanical – hydraulic efficiency
 η_t - total efficiency

DIMENSIONS

Figure 4: Outline drawing motor configuration sizes 20,21,22,23 and 112 with manifold assy.

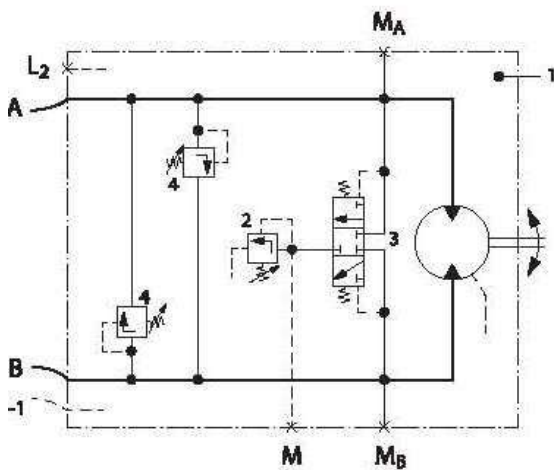
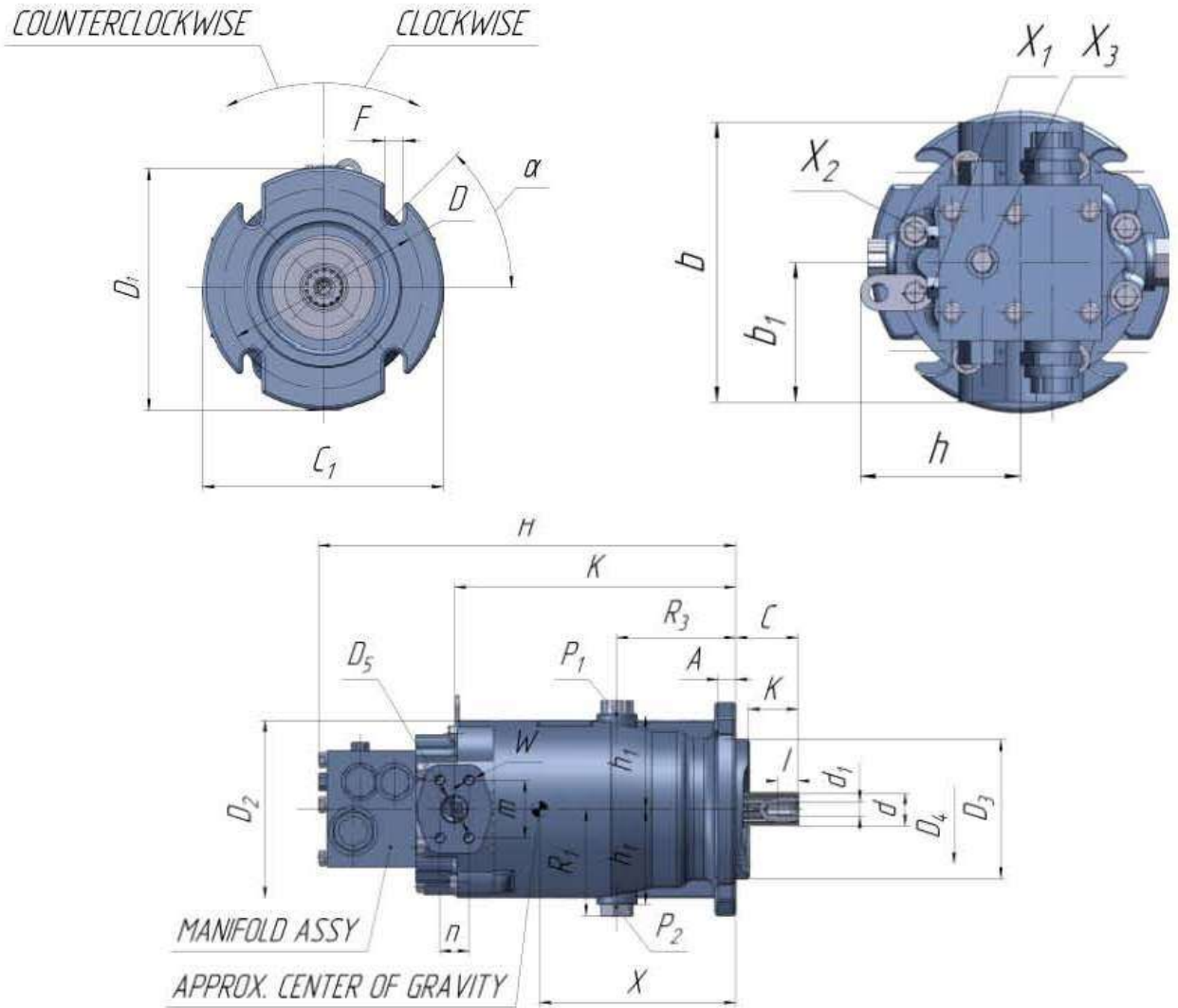

Designation :

- 1 - Fixed Displacement Motor MF
- 2 - Purge Relief Valve
- 3 - Shuttle Valve
- 4 - High Pressure Relief Valve

A, B - Main Pressure Ports

L1, L2 - Drain Ports

M - Gauge for Charge Pressure Port

MA, MB - Gauge Ports for A, B

Table 3: Dimensions (mm)

Frame size	A	C	C1	D	D1	D2	D3	D4	D5	F	H
20	15,7 ±1,5	56	190	162	146	140	127 -0,05	108	25,4	15 +0,8 -0,3	340
21	15,7 ±1,5	56	190	162	147	154	127 -0,05	108	25,4	15 +0,8 -0,3	360
22	15,7 ±1,5	56	194	162	194	161	127 -0,05	108	25,4	15 +0,8 -0,3	380
23/112	17,2 ±1,5	56	194	162	194	180	127 -0,05	108	25,4	15 +0,8 -0,3	395
24	25	75	214	229	204	200	152,4 -0,05	121	25,4	21,3 +0,8-0,3	442
25	25	77	285	317,5	254	230	165,1 -0,05	127	36,5	20,5 +0,8-0,3	542
26	27	77	281	317,5	273	271,5	165,1 -0,05	127	36,5	20,6 +0,8-0,3	572
27	38	77	298	350	298	292	177,8 -0,05	140	36,5	27	603

Frame size	H1	H2	H3	H4	H5	H6	K	P1,P2,P3	R	R1	R2	U2
20	36	252	315	277	11	25	214	7/8-14 UNF-2B	88,7	82	18	19
21	36	270	354	295	9	32	235		97	88	18	19
22	36	291	382	315	12	30	255,3		108	98	18	19
23/112	36	306	400	331	6	44	272,3		117	107	18	19
24		362	481	388,7			305		125	109		21
25		387	524	442,5			330		136,5	136		21
26		410	547				346		139,7	152		21
27		447	588	483,5			387		154	161		21

Frame size	U1	W	b	B1	d	d1	h	H1	k
20	7/8-14UNF-2B	3/8-16UNC-2B	162	82,5	34,5-0,17	M10		71	48
21			171	85,8	34,5-0,17	M10	103	76	48
22			172	86	34,5-0,17	M10	100,6	87	48
23/112			192	96	37,68-0,18	M10	115	96	48
24			214	107	44-0,18	M14		100	67
25	5/8-11UNC-2B		260	130	44-0,18	M14		124	67
26			292	146	44-0,18	M14	170	138	67
27			317	159	64,7-0,18	M16	183	146	67

Frame size	I	I1	X	P1,P2		m	n	X1, X2, X3	
20	12,5	0,2	min.20	7/8-14UNF-2B		45°	52,4	26,2	7/16-20 UNF -2B
21	12,5	0,2	min.20			45°	52,4	26,2	
22	12,5	0,2	min.20			45°	52,4	26,2	
23/112	12,5	0,2	min.20			45°	52,4	26,2	
24	12,5	0,2	min.30			45°	52,4	26,2	
25	16	0,2	min.30	15/16-12UN-2B	45°	79,4	36,5		
26	16	0,2	min.30		45°	79,4	36,5		
27	16	0,2	min.40		45°	79,4	36,5		

AXIAL PISTON FIXED MOTOR MF 25, 26, 27

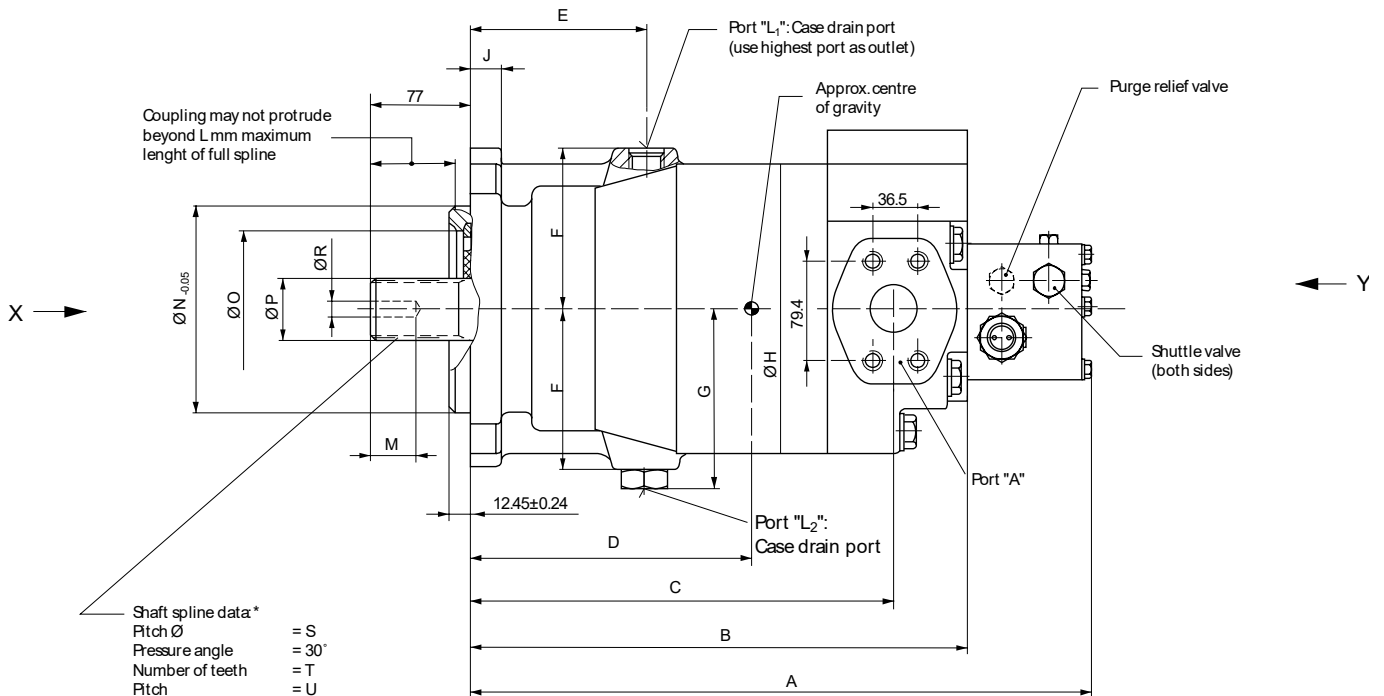

View Y

View X

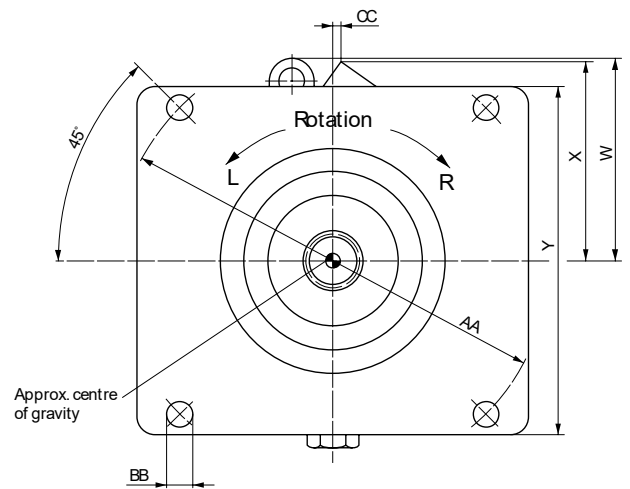
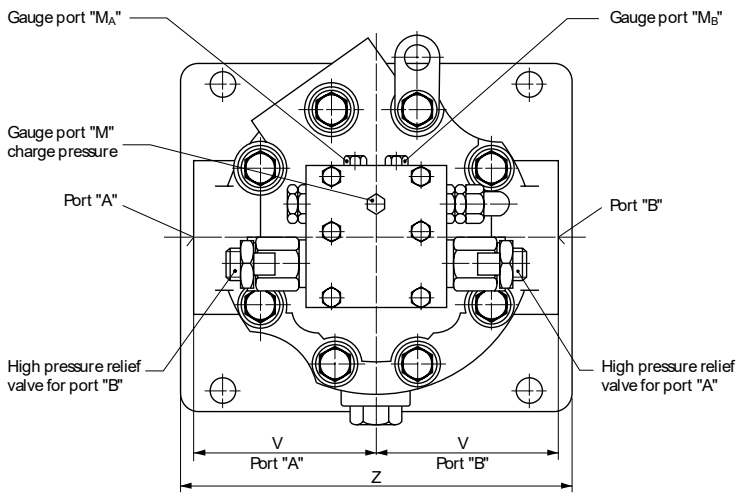

Frame size	Port A and B	Port L ₁ and L ₂	Port M _A and M _B	Port M
MF 25 / 166 cm ³	SAE flange, size 1 1/2 SAE split flange boss 6000 psi, 4 threads 5/8-11 UNC-2B 35 deep	7/16-12 UN-2B SAE straight thread O-ring boss	M 20 x 1,5	
MF 26 / 227 cm ³		1 7/8-12 UNF-2B SAE straight thread O-ring boss		
MF 27 / 334 cm ³				

Available shafts :

MF24, MF25 – 13 teeth, 27 teeth, cylindrical

MF26 – 13 teeth, 27 teeth

MF27 - 15 teeth, 40 teeth, cylindrical

DIMENSIONS

Frame size	A	B	C	D	E	F	G	Ø H	J
166	541	388	331	219	136,5	122,2	136	229	24
227	563	410	346	228.5	139,7	134,9	152	264	27
334	602	449	389	278	154	143,5	161	292	38
Frame size	M	Ø N	Ø O	Ø P	Ø R	Ø S	T	U	V
166	38,4	165,1	98	44,03 _{-0.17}	11,80	42,863	27	16/32	130,0
227	38,4	165,1	110	44,03 _{-0.17}	11,80	42,863	27	16/32	143,7
334	46,2	177,8	114	64,66 _{-0.16}	14,35	63,500	40	16/32	158,7
Frame size	W	X	Y	Z	AA	BB	CC	Diameter for shaft	Weight (kg)
166	148	145	254	285	317,5	20.6 ± 0,4	6	41,28 ^{+0,062}	124
227	156	160	265	265	317,5	20.6 ± 0,4	13	41,28 ^{+0,062}	152
334	176	174	298	298	350,0	27.0 ^{+0,5} _{-0,1}	18	41,28 ^{+0,074}	197

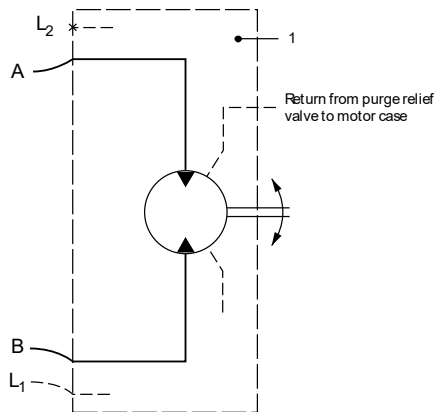
MOTOR CONFIGURATION

Designation:

1 = Fixed displacement motor

Ports:

A,B=Main pressure ports

(working loop) L1, L2 = Drain ports

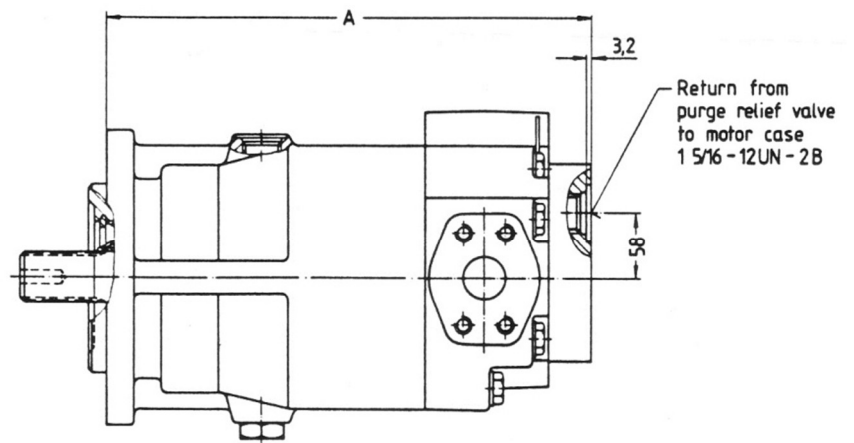
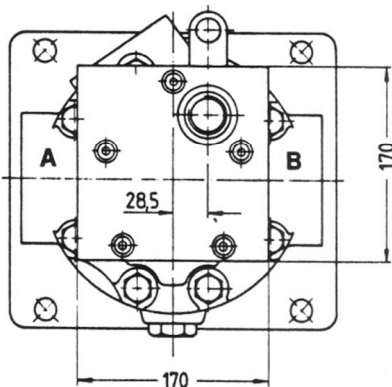

HOSE FLANGE & PIPING

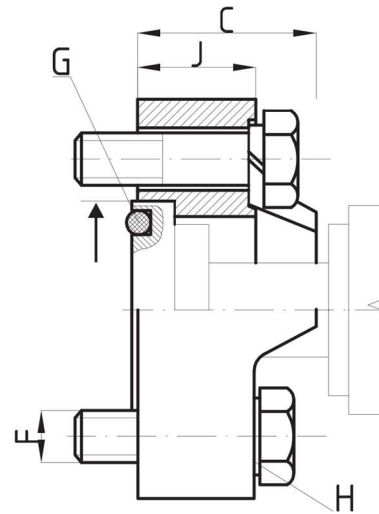
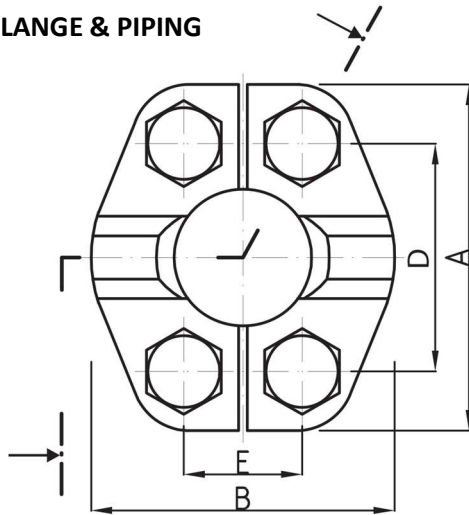

Dimensions (mm)

Frame size	PSI	A	B	C	D-0,1	E-0,1	F	H	J
20-24	5.000 PSI-(Code B)	81	70	35	52,40	26,20	3/8-16 UNC-2A	Washer 10,20	22,50
20-24	6.000 PSI-(Code A)	81	70	35	56,37	27,94	7/16-14 UNC-2B	Washer 13,20	22,50
25-27	6.000 PSI	112	95	46	79,40	36,50	5/8-11 UNC-2A	Washer 16,00	30,00

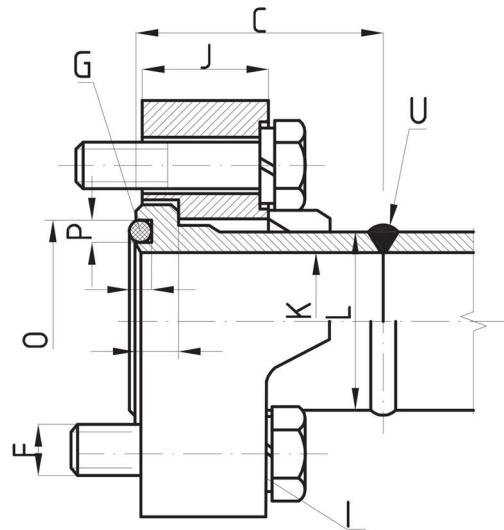
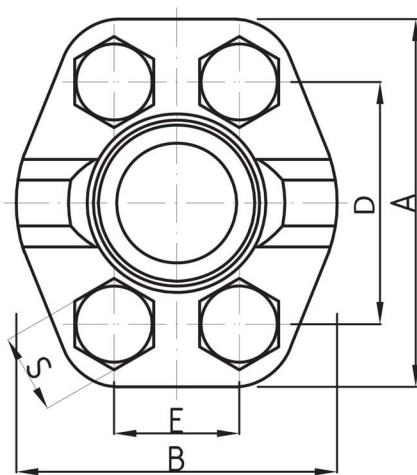

Dimensions (mm)

Frame size	PSI	A	B	C	D-0,1	E-0,1	F	H	J
20-24	5.000 PSI-(Code B)	81	70	40	52,40	26,20	3/8-16 UNC-2A	Washer 10,00	22,50
20-24	6.000 PSI-(Code A)	81	70	35	56,37	27,94	7/16-14 UNC-2B	Washer 13,20	22,50
25-27	6.000 PSI	112	95	46	79,40	36,50	5/8-11 UNC-2A	Washer 16,00	30,00

Frame size	PSI	K	L	M-0,1	N-0,1	O	P+0,2	U
20-24	5.000 PSI-(Code B)	28	38	8,00	2,80	39,7 ± 0,05	4	V5-104
20-24	6.000 PSI-(Code A)	28	38	8,00	2,80	39,7 ± 0,05	4	V5-104
25-27	6.000 PSI	38	50	12,60	2,80	53,9 ± 0,01	4	V6-158

Note:

Flange according to SAE J 518 c

Frame size 20 – 24: size 1, 5000 psi, torque for screw tightening 3/8 – 16 UNC2A: 37 – 42 Nm

Frame size 25 – 27: size 1 1/2, 6000 psi, torque for screw tightening 5/8 – 11 UNC2A: 158 – 181 Nm

MANIFOLD ASSEMBLY

Manifold assembly consists of control elements that serve to restrict working pressure in the high pressure hydrostatic circuit, to exchange the heated working fluid in closed hydrostatic circuit, to charge the volume losses in closed hydrostatic circuit as well as to secure flushing in the transmission case.

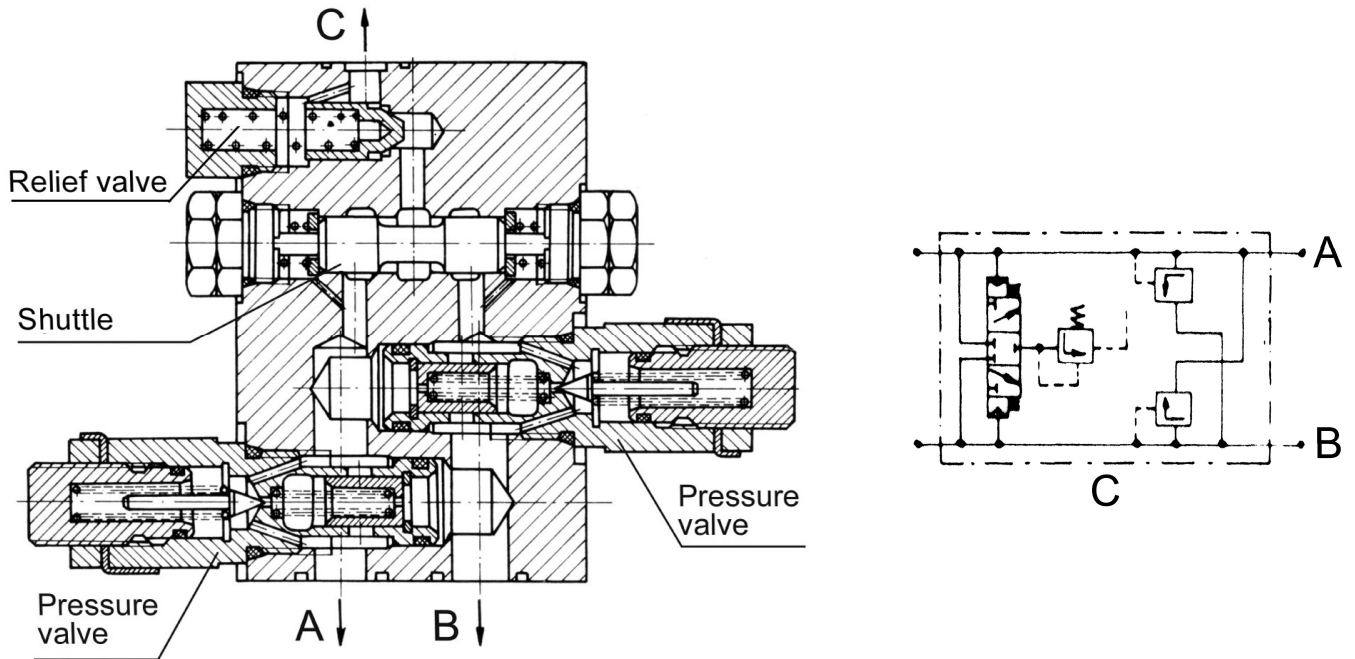

MANIFOLD ASSY WITH BY-PASS VALVE

Manifold assy with by-pass valve provides all the functions as manifold assy. On the back side there is a built-in by-pass valve designed for interconnection of high-pressure channels in closed hydrostatic circuit.

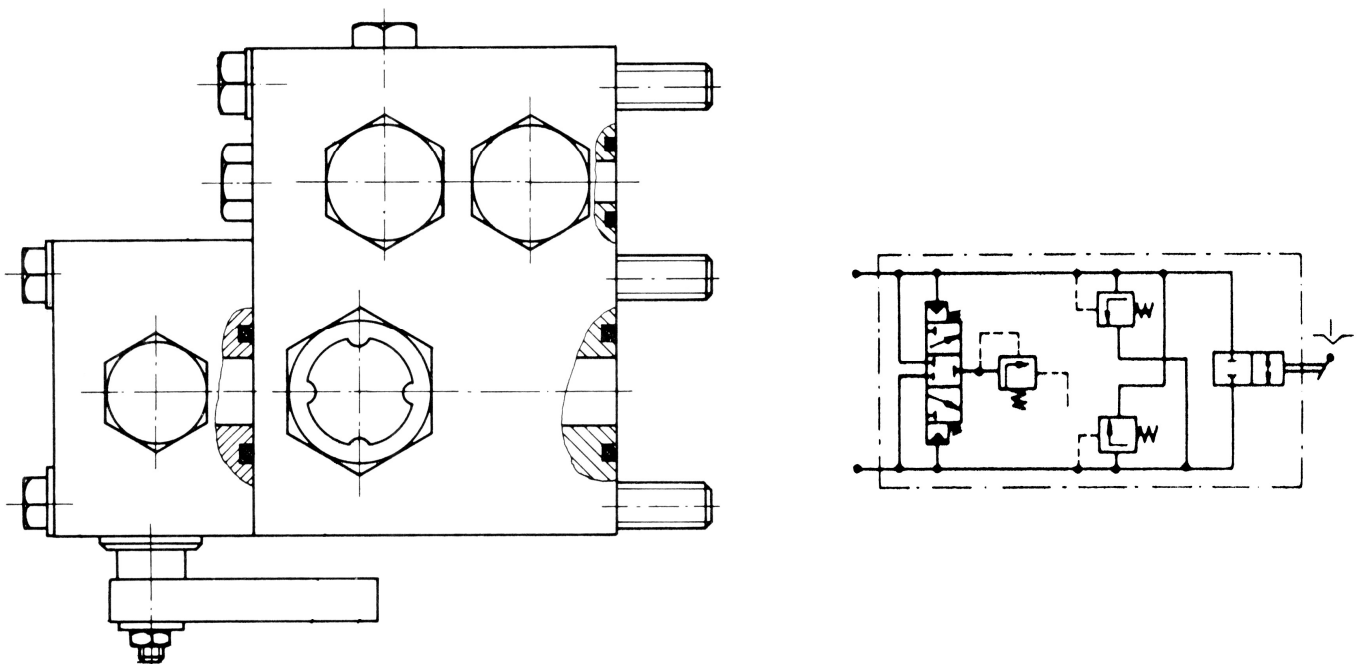

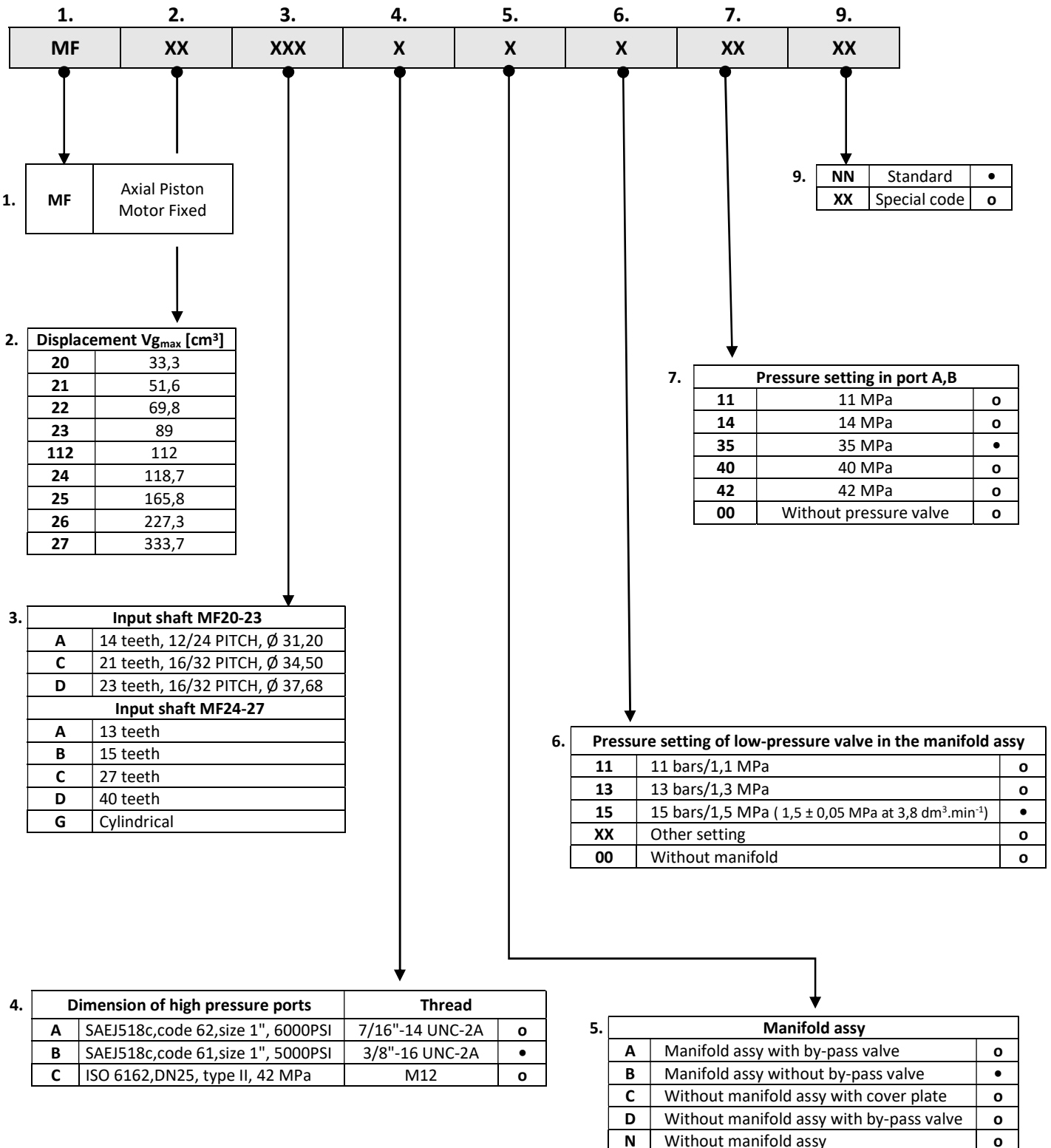
TYPE DESIGNATION OF MF - FIXED MOTORS

Ordering example : MF23 DBB1535NN

Fixed motor, 23 teeth splined shaft, pressure ports 5000 psi, manifold without by-pass, low pressure valve on 15 bars, high pressure valves on 350 bars, no special code

- standard design
- o available

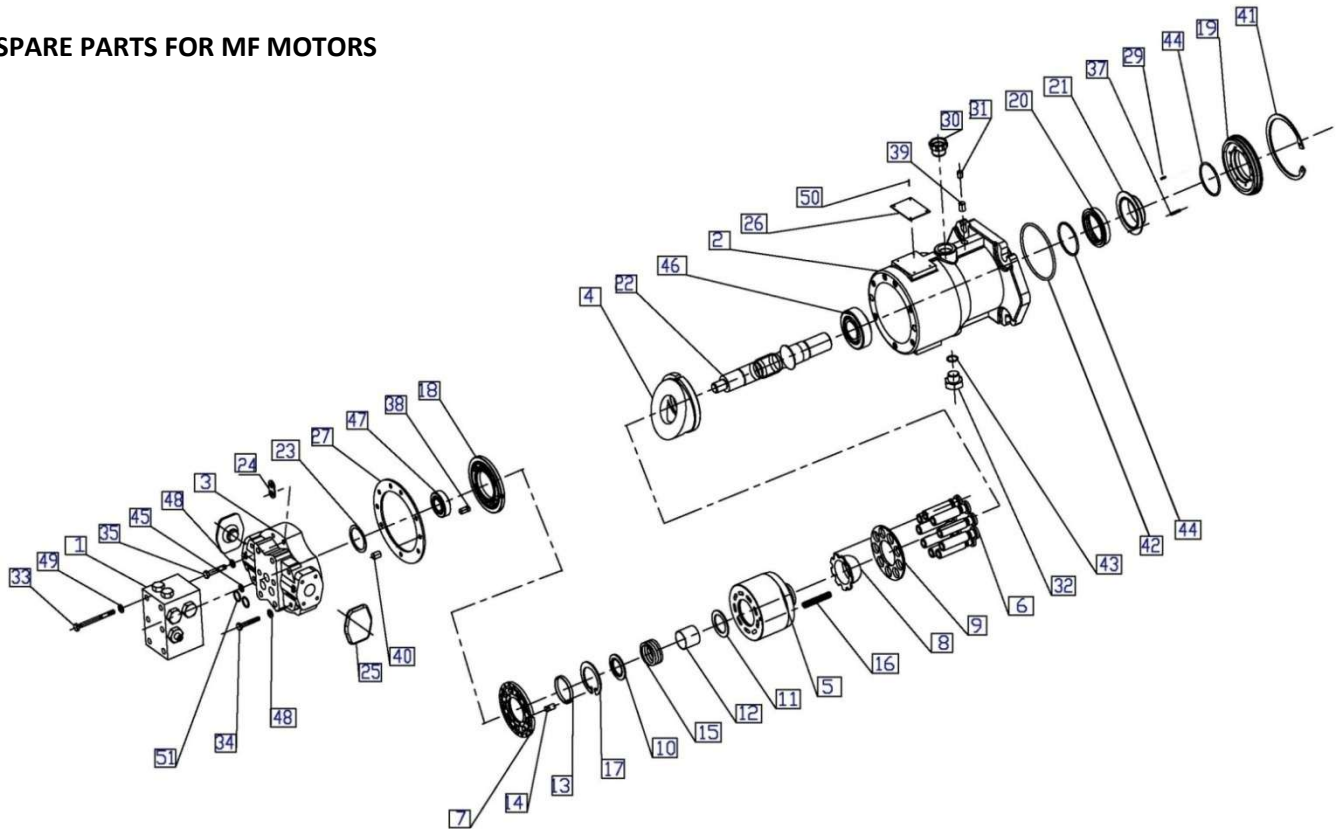
SPARE PARTS FOR MF MOTORS



Item	Pcs	Name	Item	Pcs	Name
1.	1	Manifold Assy 35 MPa	29.	6	Seal Spring
2.	1	Motor Housing	30.	1	Plug
3.	1	End Cap	31.	1	Plug
4.	1	Swash Plate	32.	1	Hex Head Plug
5.	1	Cylinder Barrel Housing	33.	6	Hex Head Screw
6.	9	Piston Assembly	34.	4	End Cap Screw
7.	1	Bearing Plate	35.	3	Hex Head Screw
8.	1	Retainer Guide	36.		Not used
9.	1	Slipper Retainer	37.	1	Drive Screw
10.	1	Spring Retainer	38.	1	Pin
11.	1	Spring Seat	39.	1	Pin
12.	1	Spring Guide	40.	2	Pin
13.	1	Bearing Plate Pilot	41.	1	Retaining Ring
14.	1	Pin	42.	1	O-Ring
15.	1	Cylinder Barrel Spring	43.	1	O-Ring
16.	6	Retainer Spring	44.	2	O-Ring
17.	1	Retainer Ring	45.	1	O-Ring
18.	1	Valve Plate	46.	1	Bearing
19.	1	Seal Retainer	47.	1	Bearing
20.	1	Rotating Seal	48.	8	Washer
21.	1	Stationary Seal	49.	6	Washer
22.	1	Drive Shaft	50.	4	Drive Screw
23.	1	Shim	51.	2	O-Ring
24.	1	Loop			
25.	2	Cap	set	1	Cylinder barrel assy - rotating group
26.	1	Not used	set	1	Set of gaskets
27.	1	End Cap Gasket	set	1	Shaft sealings set

VARIABLE MOTORS MV

Parameter		MV23	MV112
Displacement	cm ³	89,0	111,0
Minimum swashplate angle/displacement :			
7°	cm ³	33,6	41,8
9°	cm ³	43,4	53,9
10°	cm ³	48,3	60,0
11°	cm ³	53,2	66,2
13°	cm ³	63,3	78,7
Max. pressure	bar	450	
Rated pressure	bar	420	
Max. drain pressure	bar	2,5	
Max. torque	Nm	542	675
Max. speed at minimum swashplate angle	min ⁻¹	3720	
Minimum speed	min ⁻¹	500	
Rated power	kW	125,6	156,4
Weight	kg	82	84

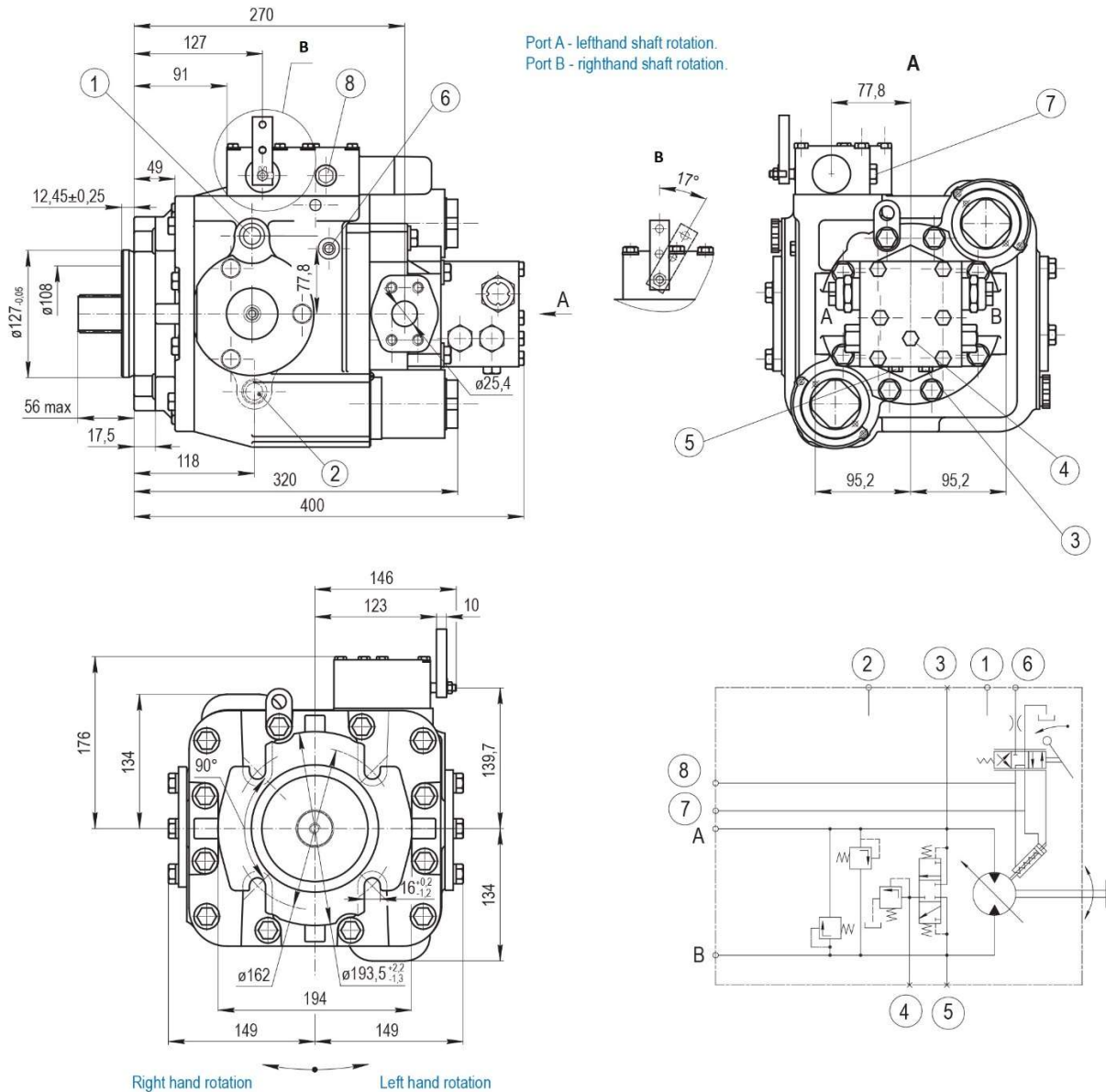

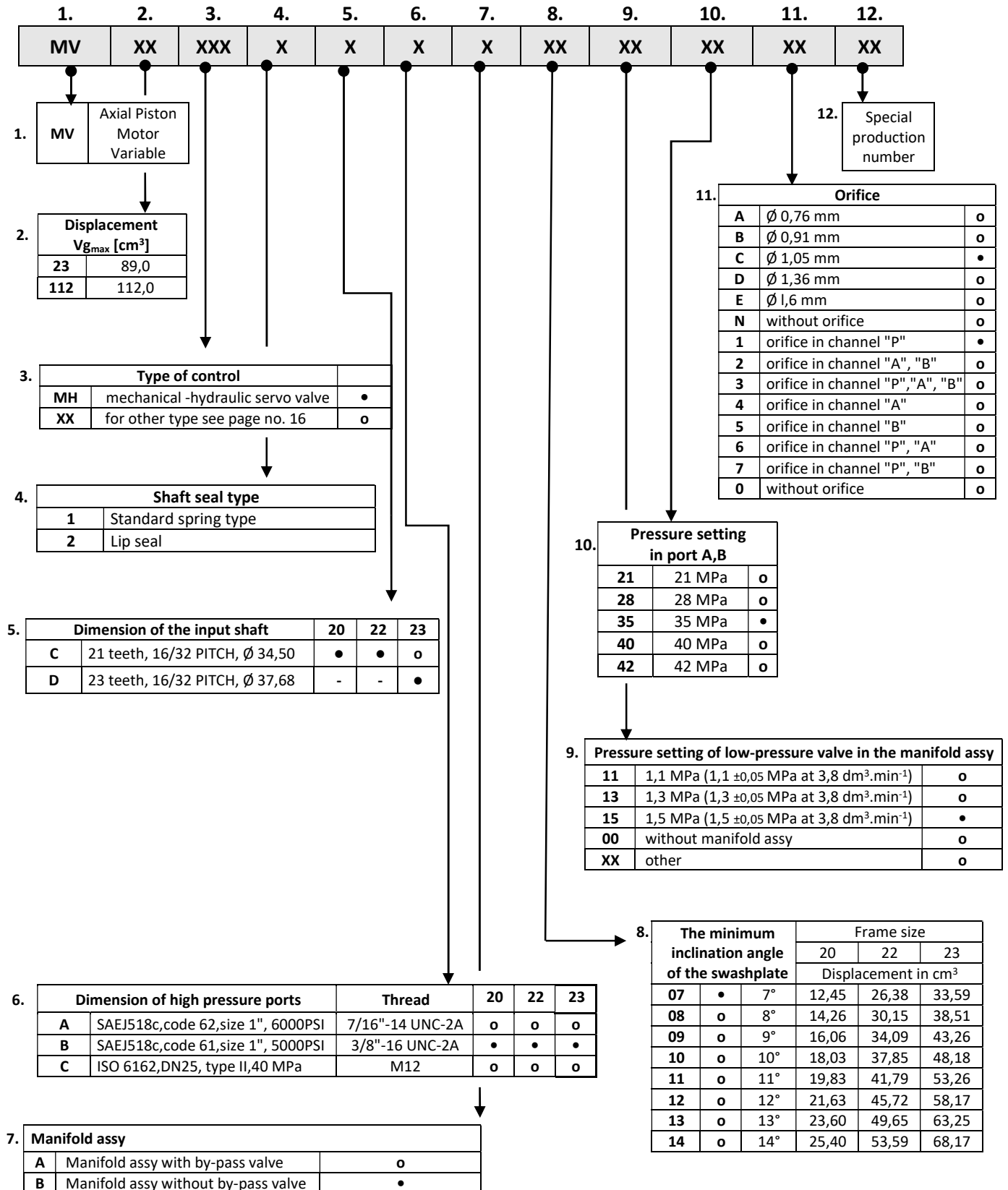
VARIABLE MOTORS MODEL CODE

• standard design o available

Ordering example : MV23 MH2DBB071535NN

Variable motor, 23 teeth shaft, lip shaft seal, standard manual displ.control, 5000 psi, manifold without by-pass, low pressure valve on 15 bars, high pressure valves on 350 bars, no special code

Axial piston fixed motors MFS – short version of MF fixed motors, wit all valve integrated into rear cover

Technical data :

Parameter	MFS 22	MFS 23	MFS112
Displacement (cm ³)	69,8	89	110,8
Max. pressure (bar)	450		
Working pressure (bar)	420		
Drain pressure (bar)	2,5		
Max. torque (Nm)	433	543	675
Max. rpm	2900		
Minim. Rpm	50		
Nominal output (kW)	96	126	157
Weight (kg)	35	35	37

Hydraulic scheme :

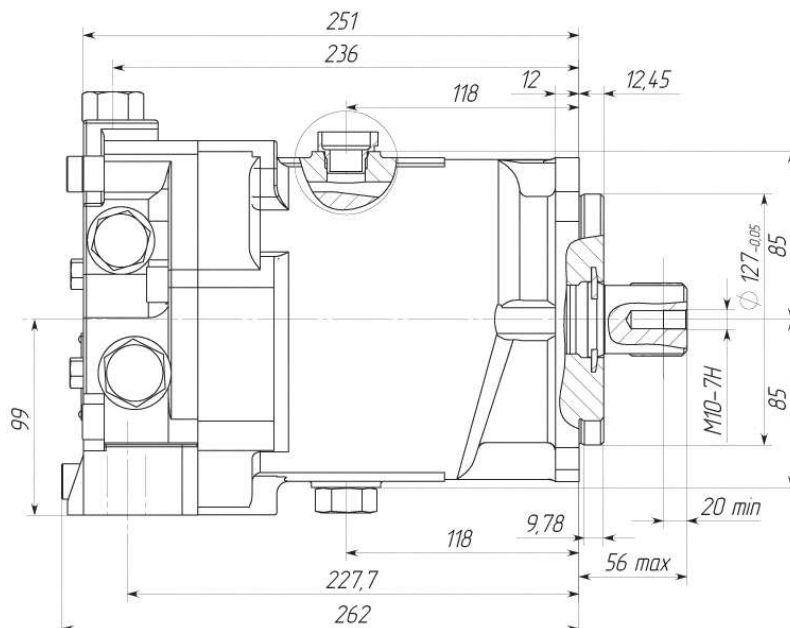
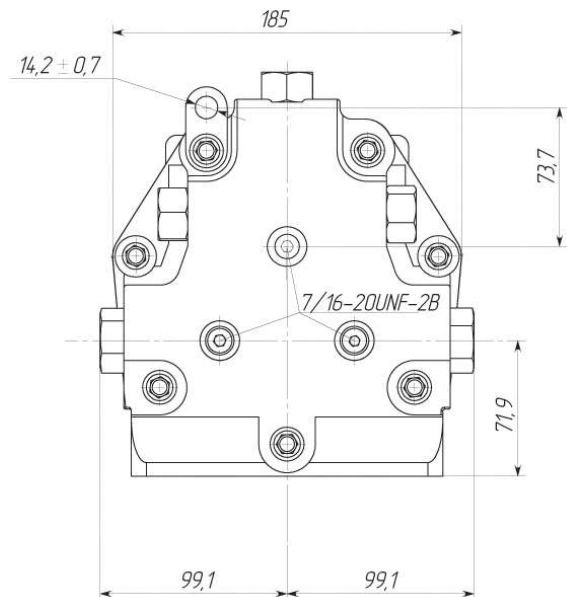
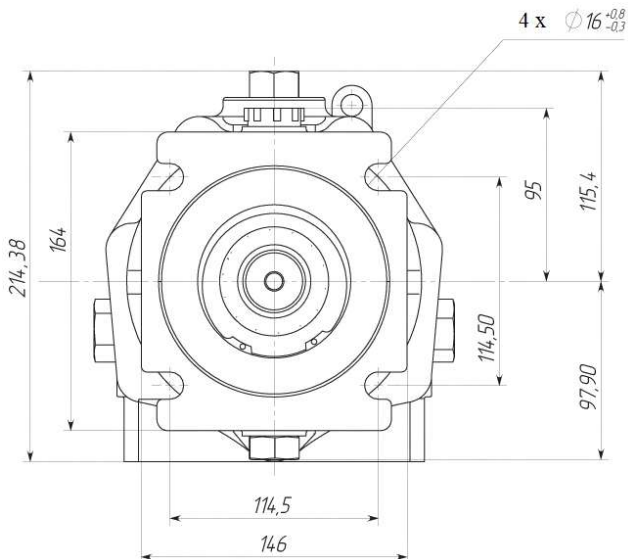
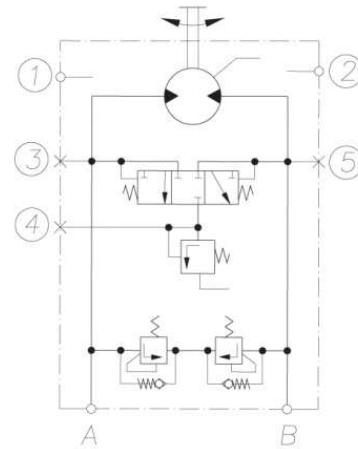

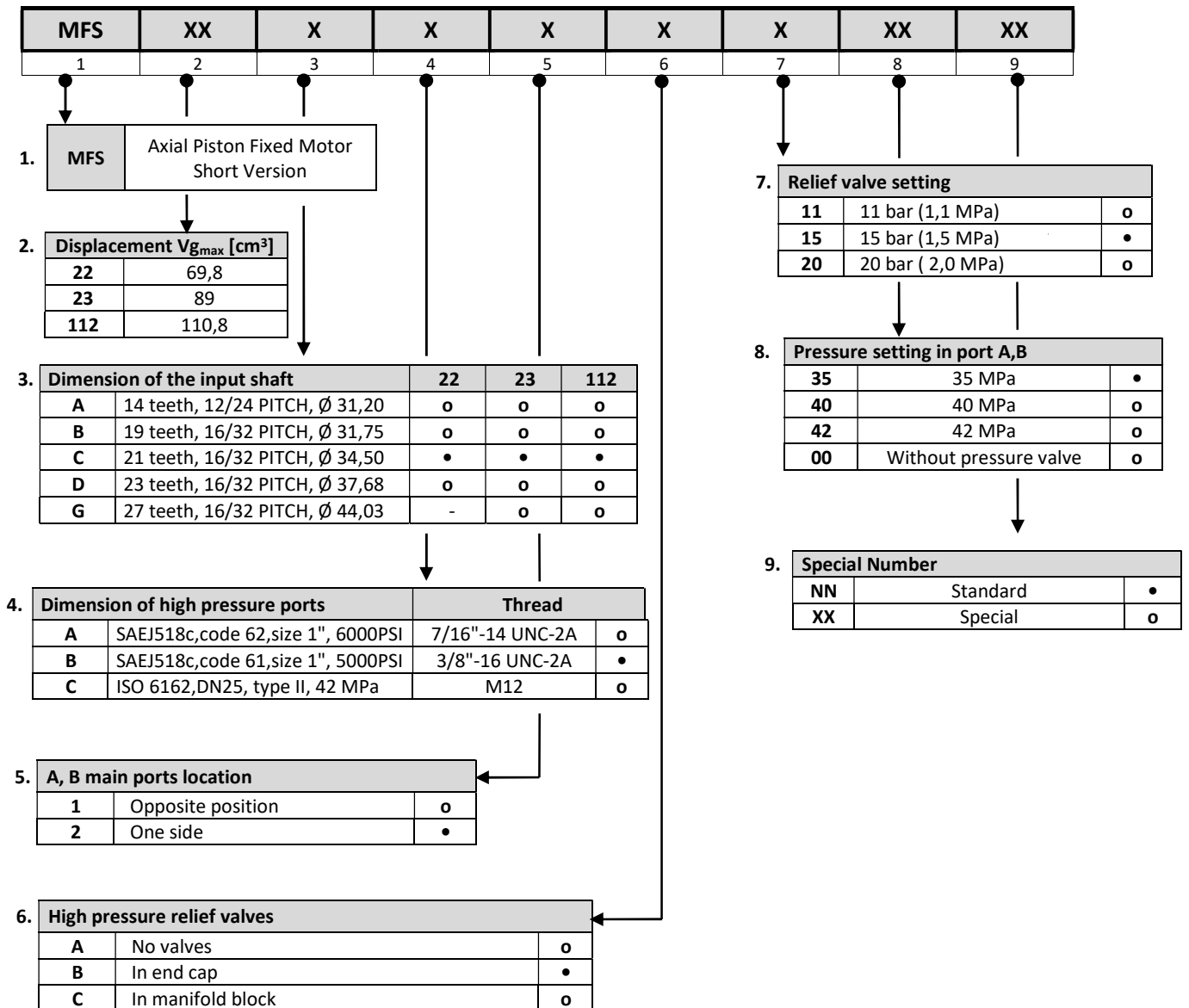
SHORT MOTORS MFS MODEL CODE

- standard design
- o available

Ordering example : MFS 23 CB2B1535NN (standard transit mixer drive motor)

- Short motor with displacement 89 cm³
- 21 teeth shaft
- Pressure ports 5000 PSI on one side
- Relief valve adjusted to 15 bar
- High pressure valves in end cap adjusted to 35 MPa
- No special code

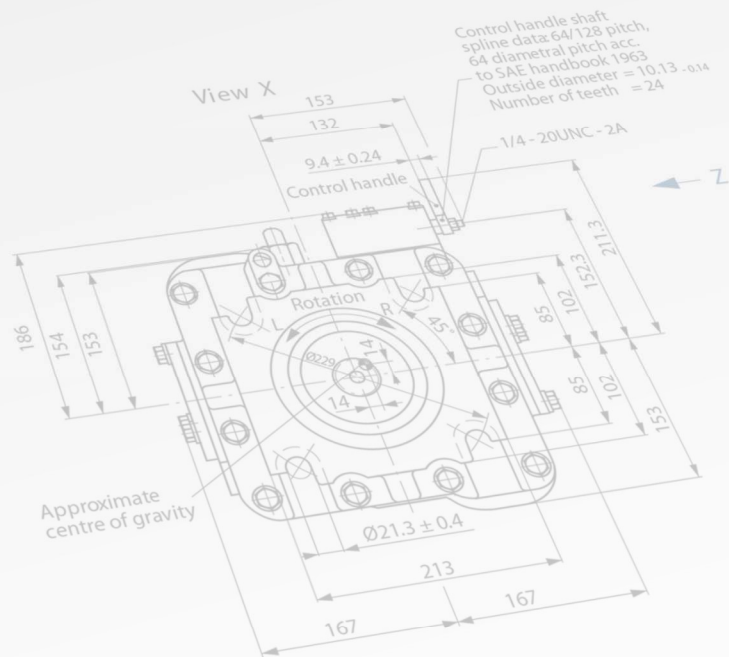
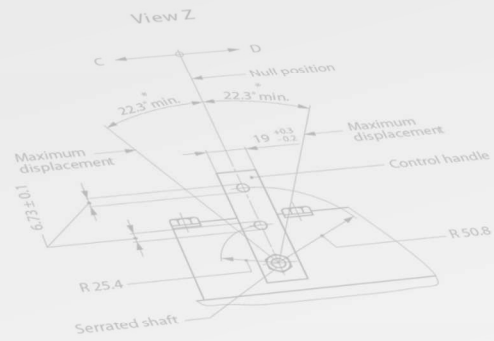
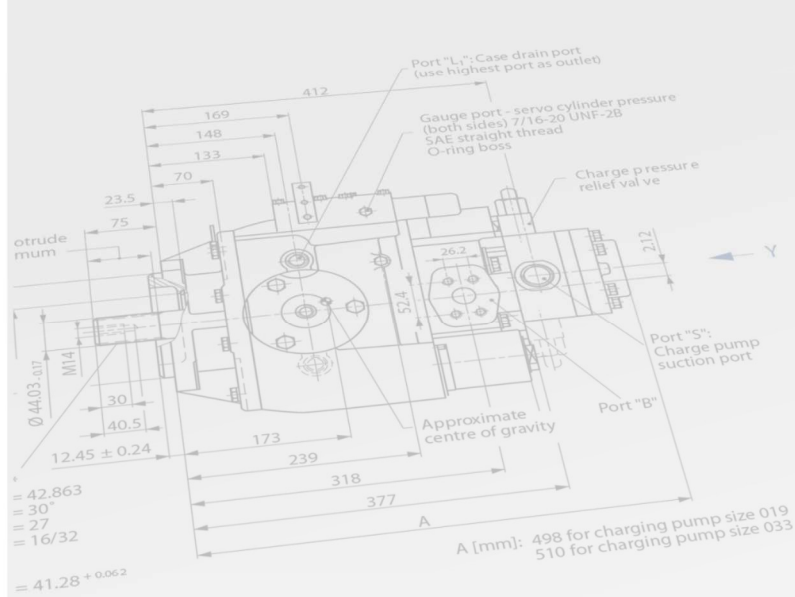

TRADEWILL Ltd.

ul. CS Armady 1

036 01 MARTIN

SLOVAK REPUBLIC

Phone & fax: +421-43-4301450

Phone : +421-905-619905

e-mail: tradewill@tradewill.sk

www.tradewill.sk